

## 2 - Prewash Hood 600mm

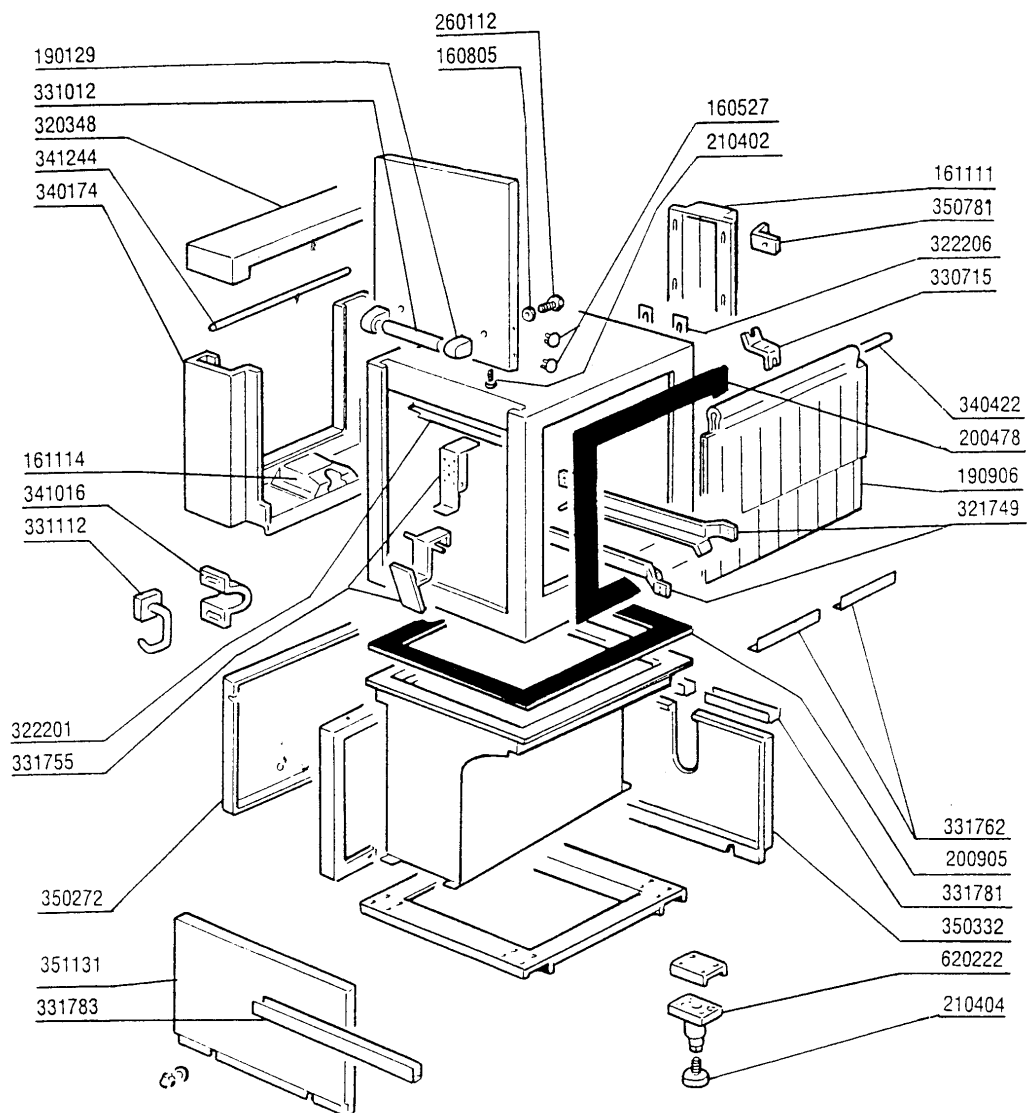

## 2 - Prewash Hood 600mm

CODE	DESCRIPTION
160527	PLUG 14,5X2X8
160805	GASKET D.8
161111	BACK COVER CHANNEL 130 N S2900
161114	END COVER OF PAWL BAR S3-S2900
190129	HANDLE SUPPORT SE NE GREY
190906	CURTAIN IN/OUT 620X480
200478	SELF-ADHESIVE GASKET 65X4
200905	SELFADHESIVE GASKET 4X35
210402	PAD FOR DOOR 15-149
210404	BLACK RUBBER FOOT S90 NE SE
260112	STAINLESS STEEL TE-SCREW 8X16
320348	BASE TOP FOR SPLASH HOOD
321749	GUIDE
322201	.
322206	HOOD REENFORCER
330715	UPPER BRACKET CURTAIN SNL-SE
331012	HANDLE 412 MM DOOR SE NE G115
331112	HOOK (331116)
331755	HOOK FOR DOOR SUPPORT
331762	BRACKET SPLASH GUARD
331781	PANEL SUPPORT 88MM
331783	PANEL SUPPORT 475MM
340174	HOOD
340422	SHAFT FOR CURTAIN AC-ACR
341016	BRACKET FOR DOOR SECURITY HOOK
341244	LEVER
350272	PANEL
350332	PREWASH PANEL
350781	BRACKET
351131	PANEL
620222	COMPLETE ALUMINIUM LEGS

3 - Wash Hood 900mm

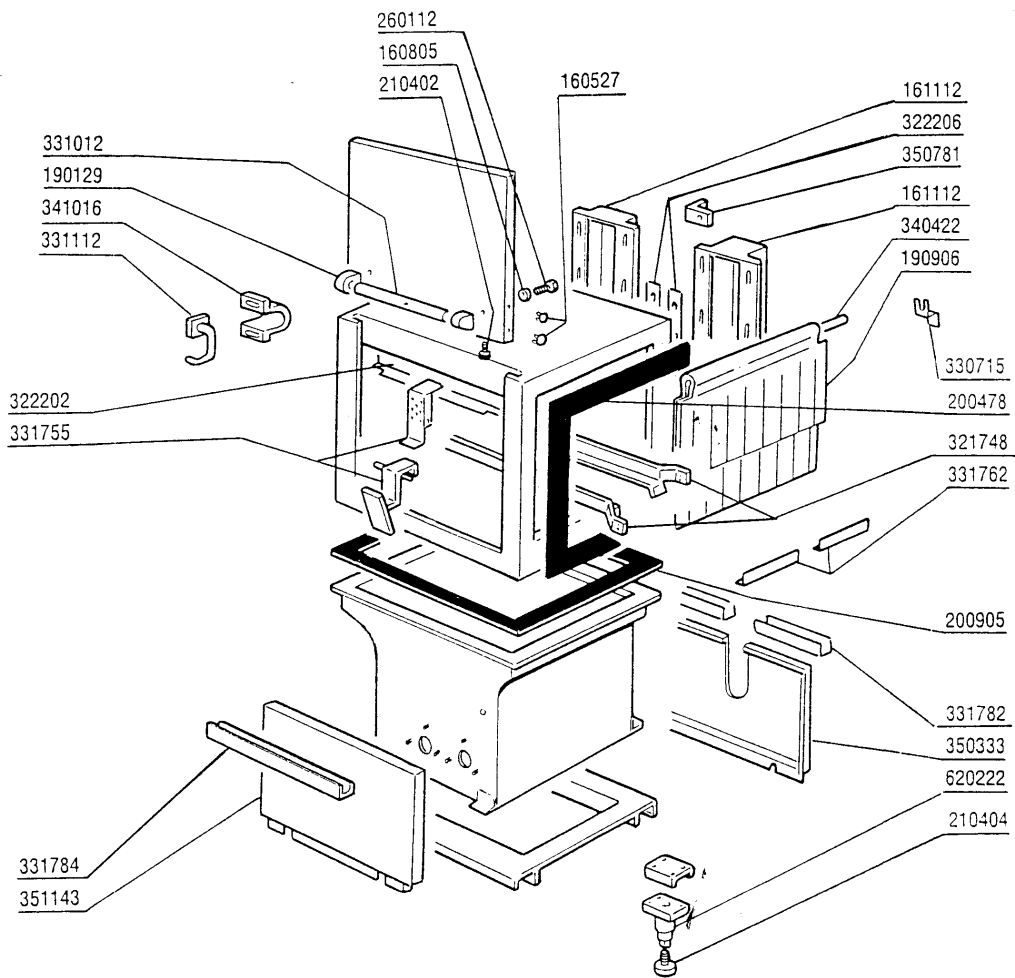

**3 - Wash Hood 900mm**

<b>CODE</b>	<b>DESCRIPTION</b>
160527	PLUG 14,5X2X8
160805	GASKET D.8
161112	BACK COVER CHANNEL 300 S N
190129	HANDLE SUPPORT SE NE GREY
190906	CURTAIN IN/OUT 620X480
200478	SELF-ADHESIVE GASKET 65X4
200905	SELFADHESIVE GASKET 4X35
210402	PAD FOR DOOR 15-149
210404	BLACK RUBBER FOOT S90 NE SE
260112	STAINLESS STEEL TE-SCREW 8X16
321748	GUIDE
322202	.
322206	HOOD REENFORCER
330715	UPPER BRACKET CURTAIN SNL-SE
331012	HANDLE 412 MM DOOR SE NE G115
331112	HOOK (331116)
331755	HOOK FOR DOOR SUPPORT
331762	BRACKET SPLASH GUARD
331782	PANEL SUPPORT 237MM
331784	PANEL SUPPORT 775MM
340422	SHAFT FOR CURTAIN AC-ACR
341016	BRAKET FOR DOOR SECURITY HOOK
350333	WASH PANEL
350781	BRACKET
351143	FRONT PANEL WASH ACR
620222	COMPLETE ALUMINIUM LEGS

4 - Ecorinse Hood

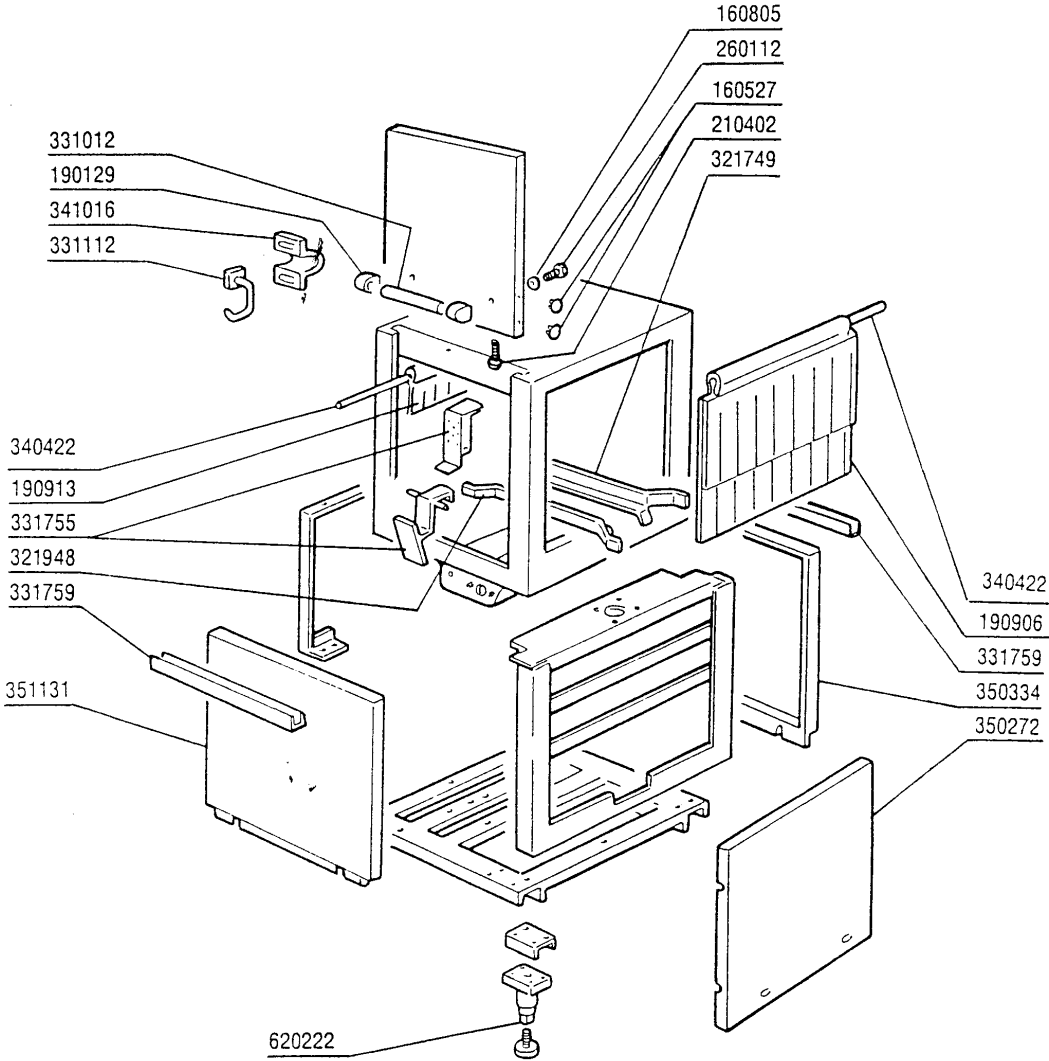

#### 4 - Ecorinse Hood

CODE	DESCRIPTION
160527	PLUG 14,5X2X8
160805	GASKET D.8
190129	HANDLE SUPPORT SE NE GREY
190906	CURTAIN IN/OUT 620X480
190913	CURTAIN FOR ECORINSE SE-620X27
210402	PAD FOR DOOR 15-149
260112	STAINLESS STEEL TE-SCREW 8X16
321749	GUIDE
321948	GUIDE
331012	HANDLE 412 MM DOOR SE NE G115
331112	HOOK (331116)
331755	HOOK FOR DOOR SUPPORT
331759	SUPPORT
340422	SHAFT FOR CURTAIN AC-ACR
341016	BRAKET FOR DOOR SECURITY HOOK
350272	PANEL
350334	ECORINSE PANEL
351131	PANEL
620222	COMPLETE ALUMINIUM LEGS

5 - Blower Dryer hood

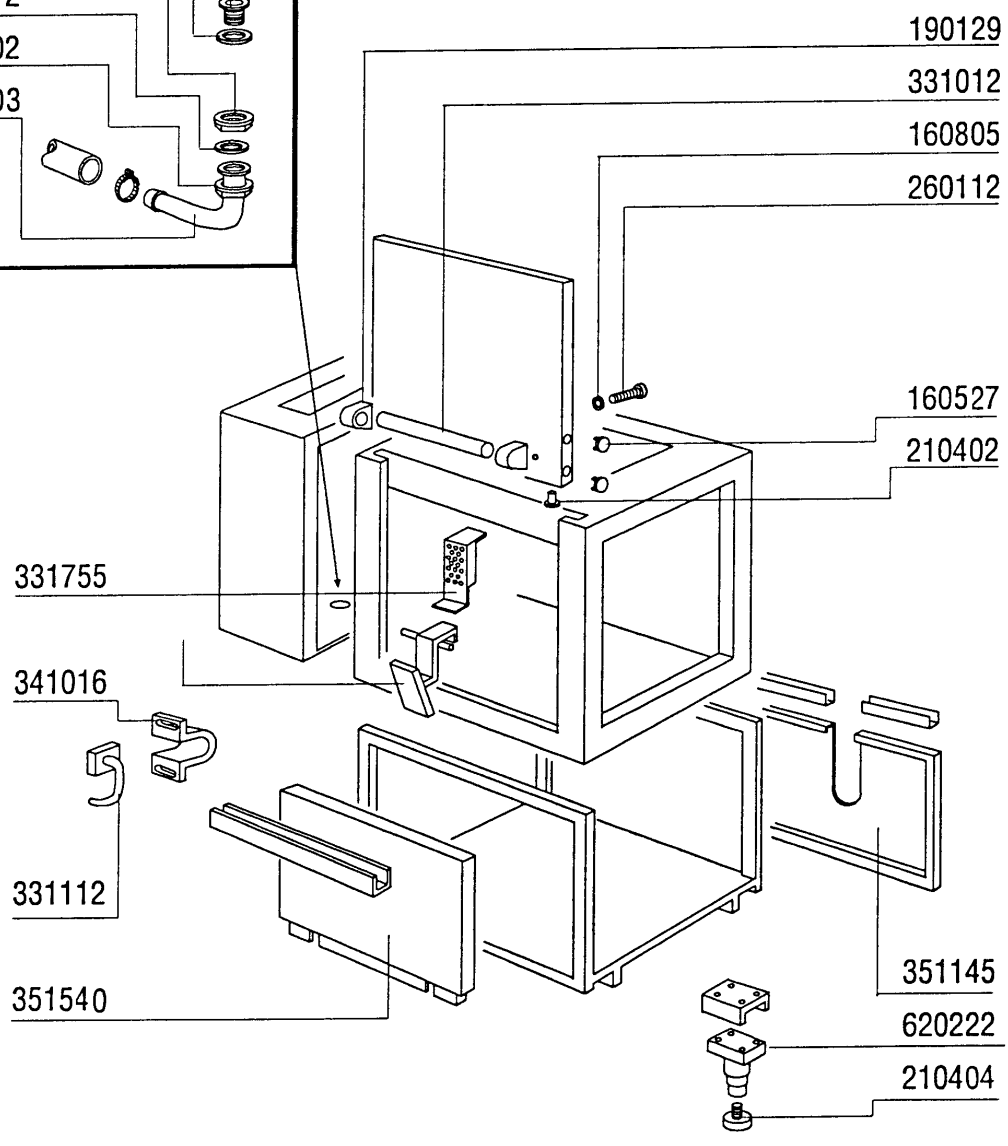
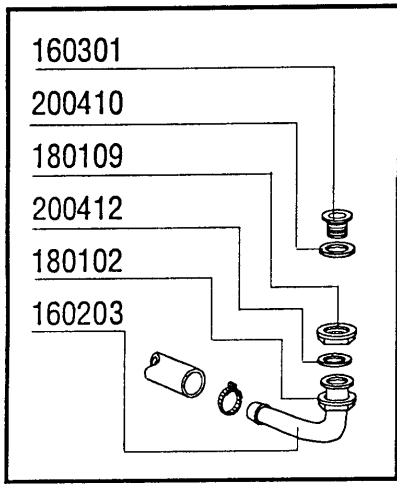

1 - 2 - 2000 01

## 5 - Blower Dryer hood

CODE	DESCRIPTION
160203	ELBOW 1"1/2 N-S-F-C /DRAIN
160301	DRAIN OUTLET 1"1/2 C-S-N
160527	PLUG 14,5X2X8
160805	GASKET D.8
180102	DRAIN PIPE NUT 1"1/2 F45-55
180109	LOCK NUT 1 1/2"
190129	HANDLE SUPPORT SE NE GREY
200410	DRAIN OUTL.WASH.1 1/2"65X47X2
200412	GASKET DRAIN 11/2" 45X33X3
210402	PAD FOR DOOR 15-149
210404	BLACK RUBBER FOOT S90 NE SE
260112	STAINLESS STEEL TE-SCREW 8X16
331012	HANDLE 412 MM DOOR SE NE G115
331112	HOOK (331116)
331755	HOOK FOR DOOR SUPPORT
341016	BRAKET FOR DOOR SECURITY HOOK
351145	PANEL
351540	EMERG. PUSH BUTTON FRONT PANEL
620222	COMPLETE ALUMINIUM LEGS



6 - Prewash Assembly 600mm

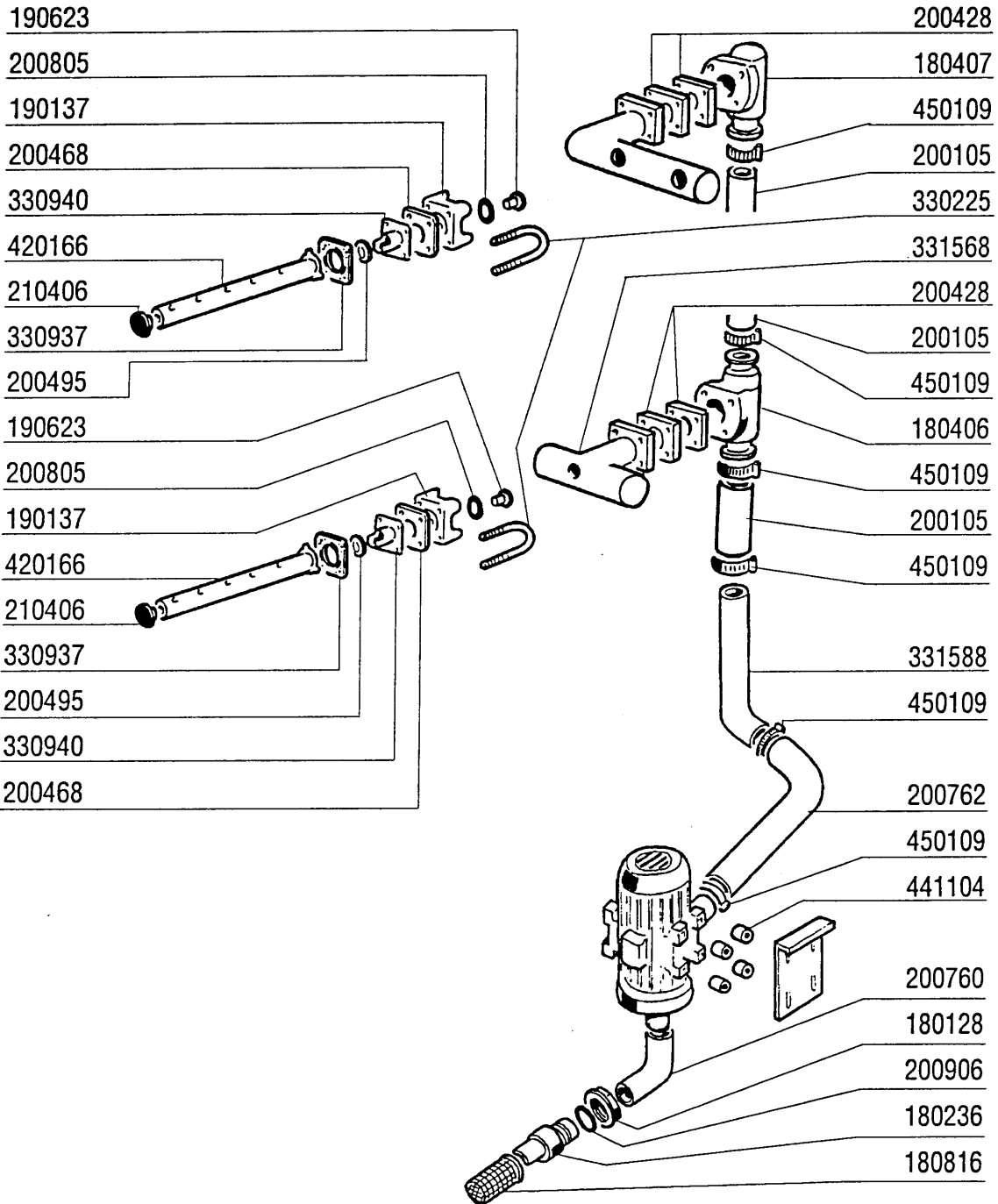

1 - 4 - 95

## 6 - Prewash Assembly 600mm

CODE	DESCRIPTION
180128	RING NUT 65,4 C140 C85
180236	PUMP SUCTION FOR AC-ACR-C155
180406	T-CONNECTOR F. WASHING S90-SNL
180407	ELBOW S90 S N L
180816	STRAINER OF INLET PUMP AC-ACR
190137	WASH ARM SUPPORT ACR
190623	RESTR.D.14 MOPL.S 3ØS PREWAS/P
200105	RUBBER HOSE 50X60
200428	GASKET 100X100X3 NEOTEN
200468	GASKET 70X70X3 NEOTEN NE
200495	GASKET FOR ACR S/S WASH ARM 43
200760	SUCTION HOSE FOR ACR
200762	DELIVERY HOSE ACR
200805	OR GASKET 2,62X28,24X33,48
200906	GASKET D.92X66X2
210406	PLUG FOR ACR WASH ARM
330225	TIE ROD ACR WASH ARM SUPPORT
330937	FLANGE
330940	FLANGE
331568	LOWER CONNECTION
331588	HOSE (332223)
420166	WASH ARM SE/1
441104	VIBRATION-DAMPING FEET FOR ACR
450109	CLAMP 50-65

7 - Wash Assembly 900mm

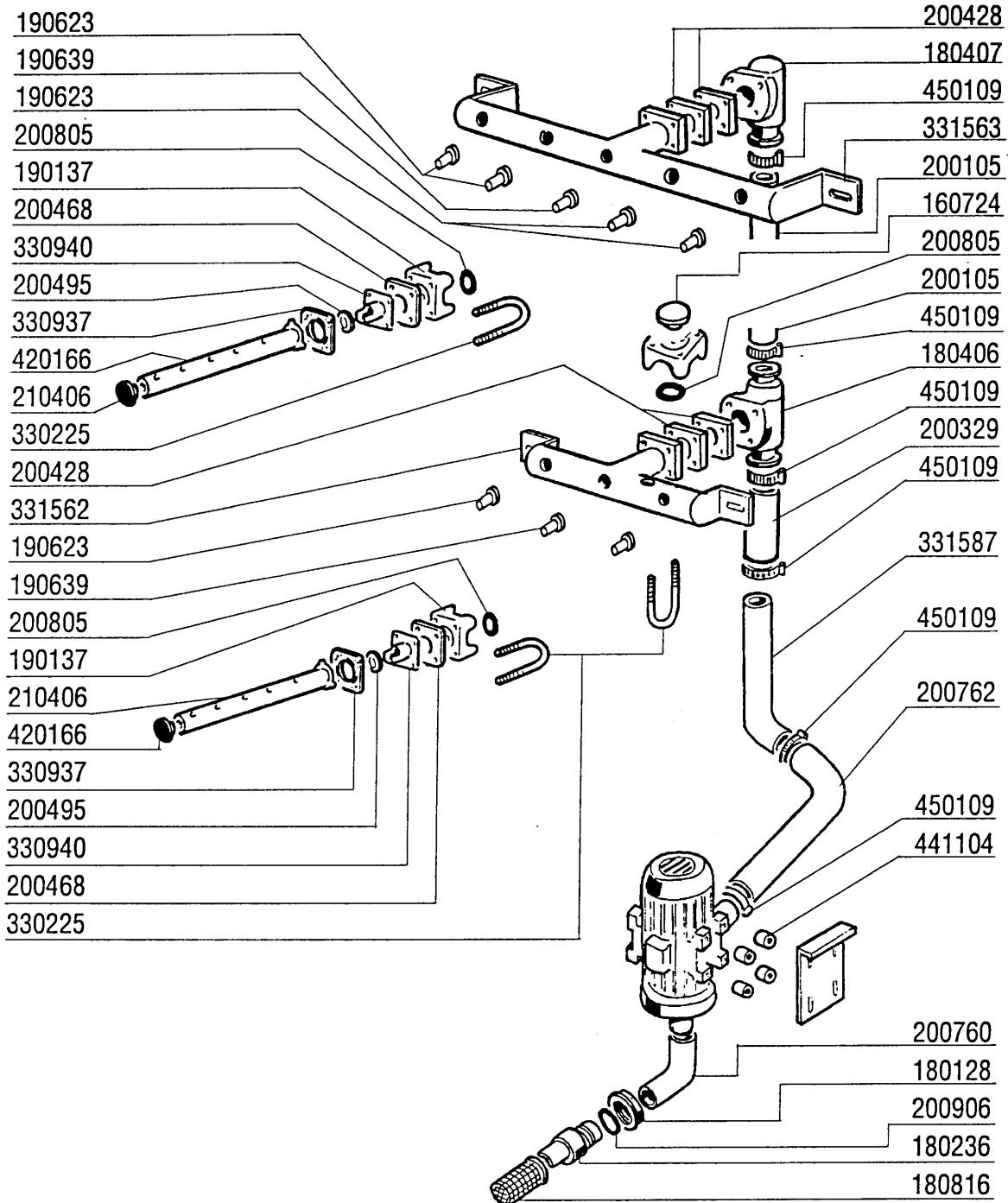

- 190623
- 190639
- 190623
- 200805
- 190137
- 200468
- 330940
- 200495
- 330937
- 420166
- 210406
- 330225
- 200428
- 331562
- 190623
- 190639
- 200805
- 190137
- 210406
- 420166
- 330937
- 200495
- 330940
- 200468
- 330225

- 200428
- 180407
- 450109
- 331563
- 200105
- 160724
- 200805
- 200105
- 450109
- 180406
- 450109
- 200329
- 450109
- 331587
- 450109
- 200762
- 450109
- 441104
- 200760
- 180128
- 200906
- 180236
- 180816

1 - 4 - 95

## 7 - Wash Assembly 900mm

CODE	DESCRIPTION
160724	PLUG F. WASH ARM S90
180128	RING NUT 65,4 C140 C85
180236	PUMP SUCTION FOR AC-ACR-C155
180406	T-CONNECTOR F. WASHING S90-SNL
180407	ELBOW S90 S N L
180816	STRAINER OF INLET PUMP AC-ACR
190137	WASH ARM SUPPORT ACR
190623	RESTR.D.14 MOPL.S 3ØS PREWAS/P
190639	REDUCTION BUSH D.16
200105	RUBBER HOSE 50X60
200329	HOSE
200428	GASKET 100X100X3 NEOTEN
200468	GASKET 70X70X3 NEOTEN NE
200495	GASKET FOR ACR S/S WASH ARM 43
200760	SUCTION HOSE FOR ACR
200762	DELIVERY HOSE ACR
200805	OR GASKET 2,62X28,24X33,48
200906	GASKET D.92X66X2
210406	PLUG FOR ACR WASH ARM
330225	TIE ROD ACR WASH ARM SUPPORT
330937	FLANGE
330940	FLANGE
331562	CONNEC.ELBOW F.LOWER WASH
331563	CONNEC.ELBOW F.UPPER WASH
331587	DELIVERY ELBOW AC-ACR WASH
420166	WASH ARM SE/1
441104	VIBRATION-DAMPING FEET FOR ACR
450109	CLAMP 50-65

# 8 - Ecorinse Assembly

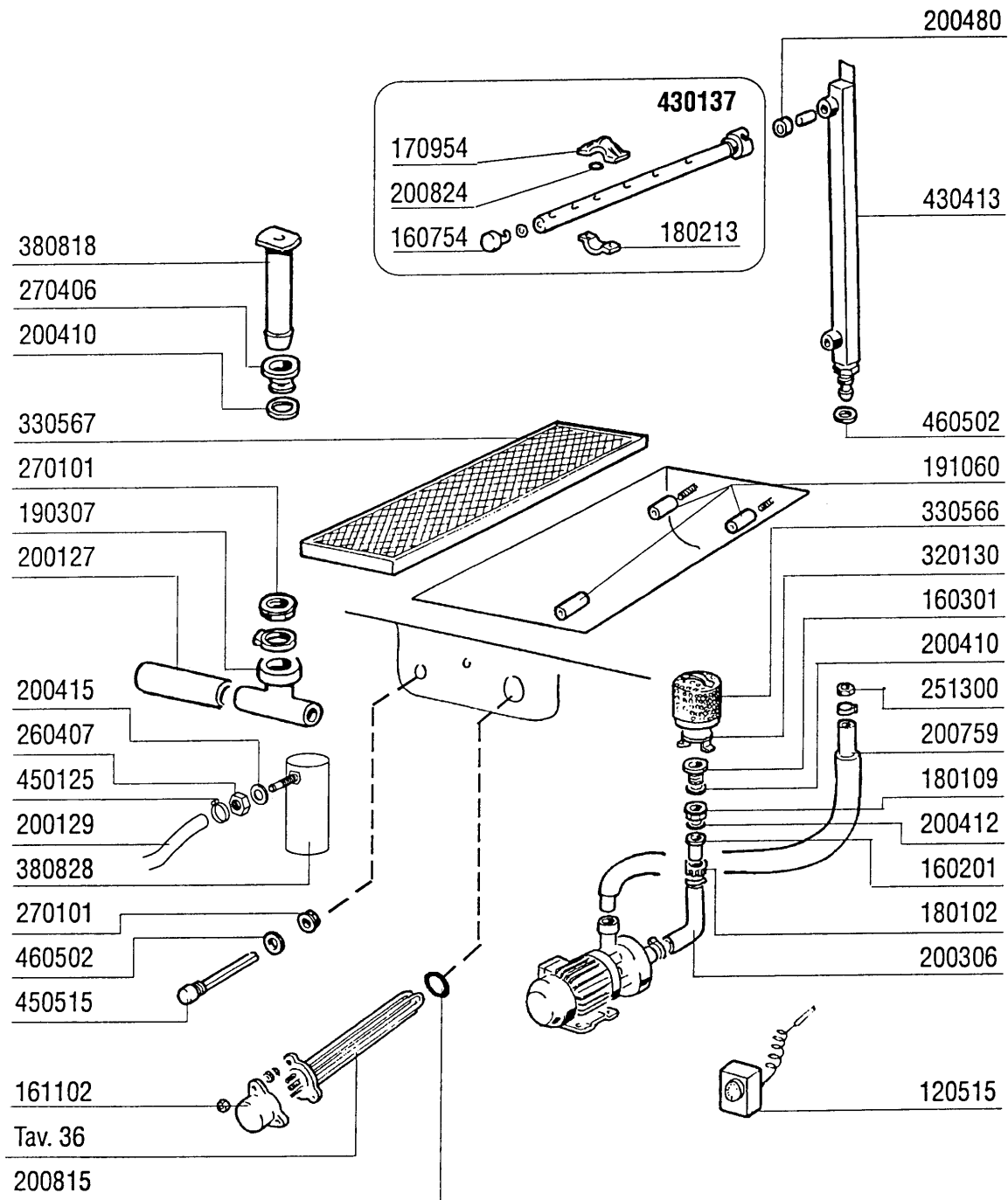

1 - 4 - 95 01

## 8 - Ecorinse Assembly

CODE	DESCRIPTION
120515	THERMOSTAT 0-90°C
160201	ELBOW F.TANK INLET MOPLN
160301	DRAIN OUTLET 1"1/2 C-S-N
160754	PLUG FOR RINSE ARMS SE NE
161102	ELEMENT COVER MOPL.
170954	JET FOR ECORINSE ARM
180102	DRAIN PIPE NUT 1"1/2 F45-55
180109	LOCK NUT 1 1/2"
180213	FLANGE F.JET LOCKING F2-C34
190307	SPECIAL TEE GRAU MPL.
191060	HOLDER PIN FOR ECORINSE FILTER
200127	PVC HOSE D.35
200129	HOSE 5X11 FOR PRESSURE SWITCH
200306	INLET HOSE 42X52 ECORINSE-DRAI
200410	DRAIN OUTL.WASH.1 1/2"65X47X2
200412	GASKET DRAIN 11/2" 45X33X3
200415	AIR TRAP GASKET -F2 18,5X10X3
200480	GASKET F. RINSE CONNECT.
200759	DELIVERY HOSE FOR ECORINSE AC-
200815	O-RING F. HEAT.ELEM.
200824	O-RING 1,78X12,42X15,98
251300	S/S LOCK NUT 1/2" AC-ACR
260407	STAINLESS STEEL NUTS D10 UNI 5
270101	HEXAGON LOCK NUT 1/2"
270406	ECORINSE DRAIN OUTLET
320130	VORTEX BREAKER FOR ECORINSE PU
330566	FILTER 110 FOR ECORINSE TANK
330567	STANDARD RINSE FILTER SE
380818	OVERFLOW TUBE FOR ECORINSE SE
380828	ECORINSE AIR CHAMBER AC-ACR ST
430137	ECORINSE ARM SE-SE/1
430413	RINSE COLUMN SE-ACR
450125	ELASTIC CLAMP D. 10,4X9,8
450515	STAINL.ST.SHIELD FOR 1 THERMOS
460502	GASKET 30X21X2

## 9 - Rinse assembly

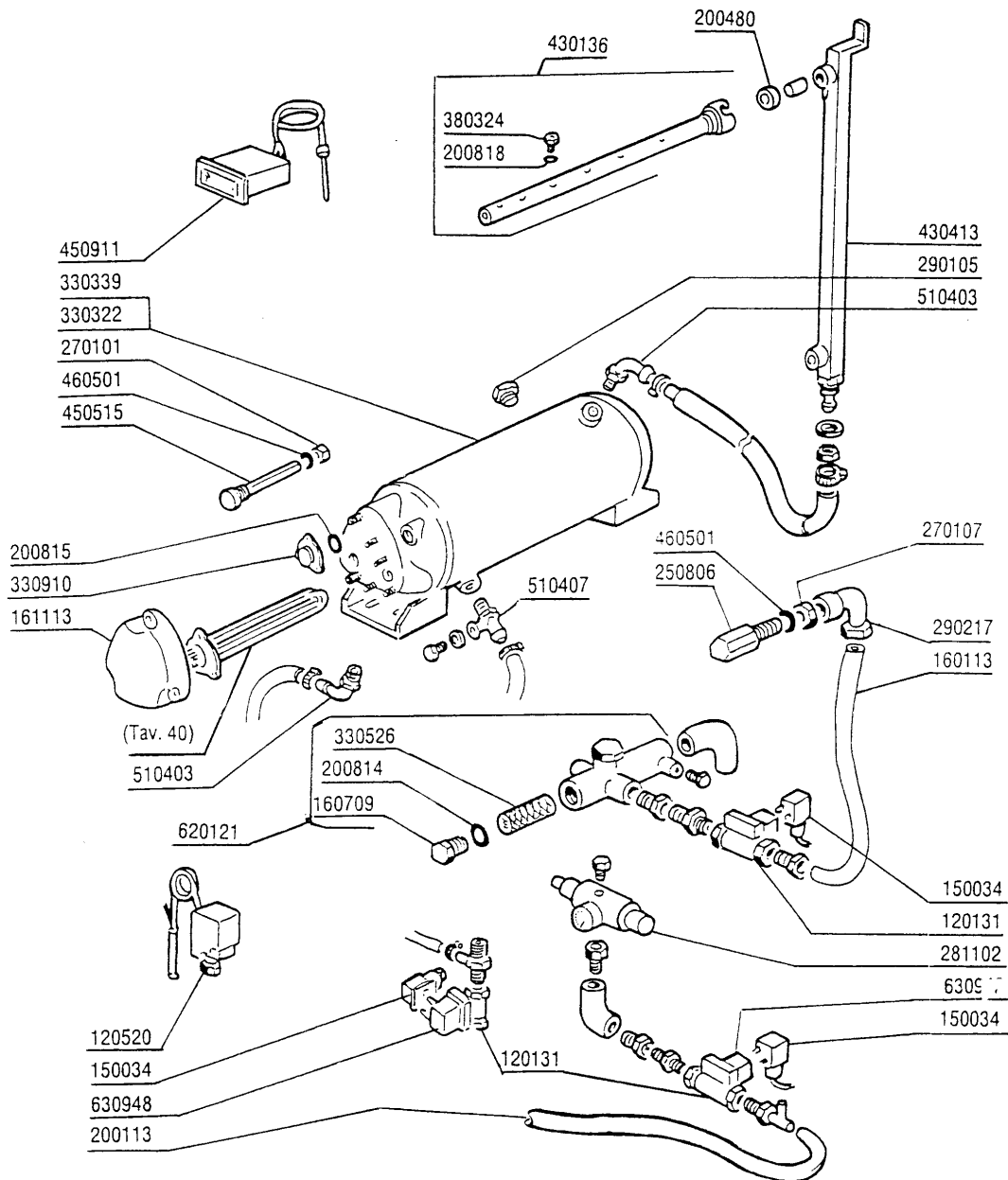

## 9 - Rinse assembly

CODE	DESCRIPTION
120131	SOLEN. L182Q31-ZB10A 1/2"24V
120520	SECURITY THERMOSTAT 110-130Ø
150034	CONNec.F.SOLEN.VALVE 122.09.N
160113	TUBE IN POL. RETIC. 12 EST
160709	KNOB OF MANIFOLD F. SOLEN. VAL
161113	ELEMENT COVER BLACK
200113	RUBBER HOSE 12 X 22
200480	GASKET F. RINSE CONNECT.
200814	O-RING 34,52X41,58X3,53
200815	O-RING F. HEAT.ELEM.
200818	O-RING 1,78 X 6,75 X 10,31
250806	TANK FILL HOSE CLAMP - AC/ACR
270101	HEXAGON LOCK NUT 1/2"
270107	BRASS LOCK NUT 3/8" FL803
281102	1/2" ADJ VALVE C/W GAUGE TYPE
290105	BRASS-TE-PLUG 1/2"
290217	HOSE CLAMP ELBOW 12X3/8" TYPE
330322	INSULATED BOILER D.230 N/S
330339	BOILER D.220X640 F.TWO HEAT.EL
330526	FILTERS 22X28 SOLENOID V.MANIF
330910	FLANGE
380324	RINSE JETS 52,5 80Ø OV1/8"
430136	RINSE ARM S-SE-SE/1
430413	RINSE COLUMN SE-ACR
450515	STAINL.ST.SHIELD FOR 1 THERMOS
450911	DIGITAL THERMOSTAT MTR10P 24/5
460501	GASKET 24X17X2
510403	CONNECT.HOSE 90Ø1/2"X12
510407	NIPPLE FOR BOILER N S
620121	TWIN SOLENOID VALVE MANIFOLD
630948	COIL Z610A 24V 50/60-L180V01



10 - Prewash tank components 600mm

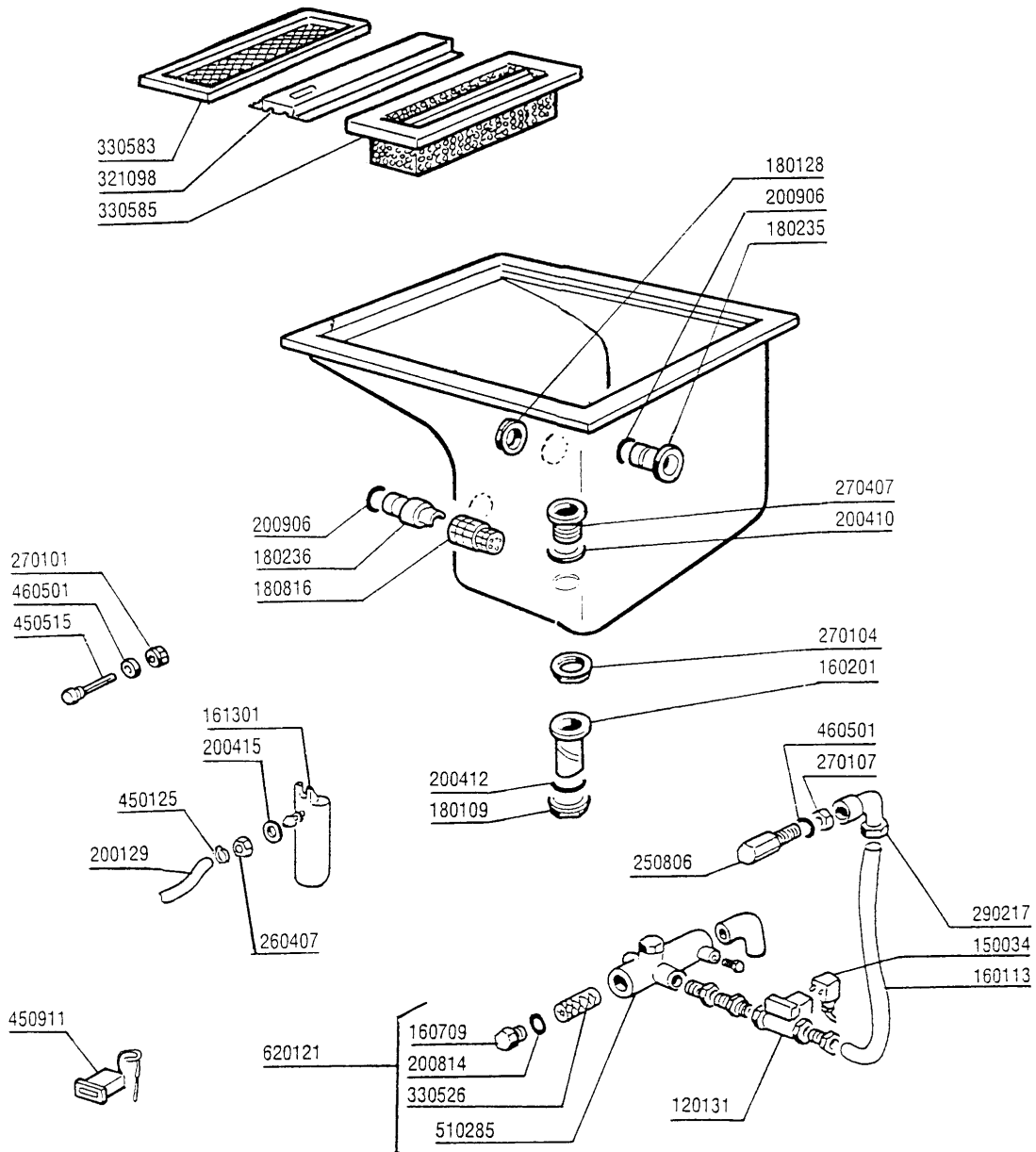

## 10 - Prewash tank components 600mm

CODE	DESCRIPTION
120131	SOLEN. L182Q31-ZB10A 1/2"24V
150034	CONNEC.F.SOLEN.VALVE 122.09.N
160113	TUBE IN POL. RETIC. 12 EST
160201	ELBOW F.TANK INLET MOPLEN
160709	KNOB OF MANIFOLD F. SOLEN. VAL
161301	AIR TRAP F2 C34-F45
180109	LOCK NUT 1 1/2"
180128	RING NUT 65,4 C140 C85
180235	PUMP SUCTION C85-140
180236	PUMP SUCTION FOR AC-ACR-C155
180816	STRAINER OF INLET PUMP AC-ACR
200129	HOSE 5X11 FOR PRESSURE SWITCH
200410	DRAIN OUTL.WASH.1 1/2"65X47X2
200412	GASKET DRAIN 11/2" 45X33X3
200415	AIR TRAP GASKET -F2 18,5X10X3
200814	O-RING 34,52X41,58X3,53
200906	GASKET D.92X66X2
250806	TANK FILL HOSE CLAMP - AC/ACR
260407	STAINLESS STEEL NUTS D10 UNI 5
270101	HEXAGON LOCK NUT 1/2"
270104	LOCK NUT 1" 1/2
270107	BRASS LOCK NUT 3/8" FL803
270407	TANK DRAIN OUTLET ACR
290217	HOSE CLAMP ELBOW 12X3/8" TYPE
321098	SUPPORT
330526	FILTERS 22X28 SOLENOID V.MANIF
330583	PREWASH FILTER AC/ACR
330585	PREWASH DRAWER FILTER AC-ACR
450125	ELASTIC CLAMP D. 10,4X9,8
450515	STAINL.ST.SHIELD FOR 1 THERMOS
450911	DIGITAL THERMOSTAT MTR10P 24/5
460501	GASKET 24X17X2
510285	SOLENOID VALVE MANIFOLD - BRAS
620121	TWIN SOLENOID VALVE MANIFOLD

11 - Prewash tank components 600mm

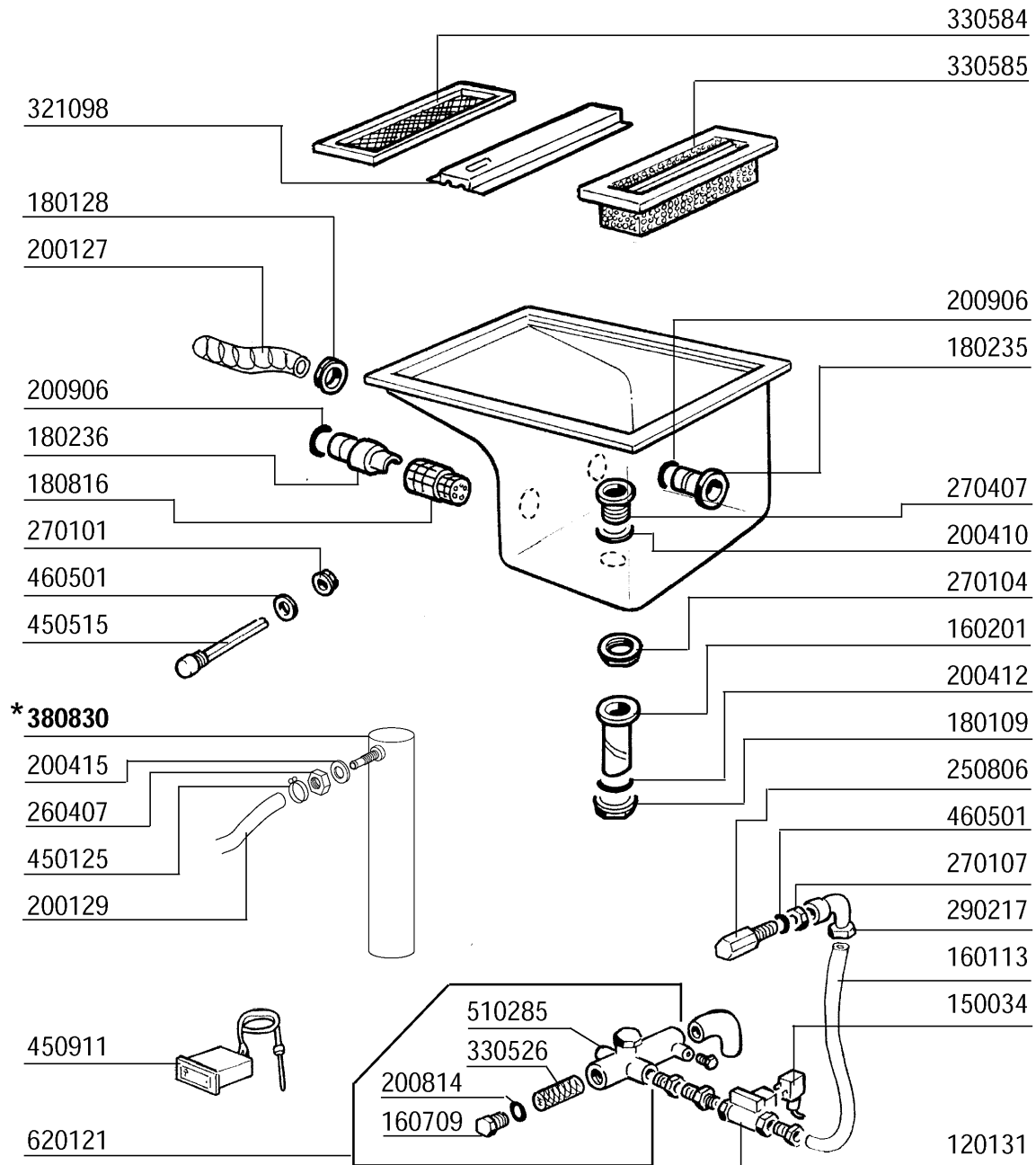

1 - 4 - 95 01

\* Dalla matricola:  
 \* A partir da la matr.  
 \* From serial no.  
 \* Ab Seriennr.  
 \* Despues la matr.

94865/94

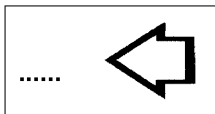

## 11 - Prewash tank components 600mm

CODE	DESCRIPTION
120131	SOLEN. L182Q31-ZB10A 1/2"24V
150034	CONNEC.F.SOLEN.VALVE 122.09.N
160113	TUBE IN POL. RETIC. 12 EST
160201	ELBOW F.TANK INLET MOPLEN
160709	KNOB OF MANIFOLD F. SOLEN. VAL
180109	LOCK NUT 1 1/2"
180128	RING NUT 65,4 C140 C85
180235	PUMP SUCTION C85-140
180236	PUMP SUCTION FOR AC-ACR-C155
180816	STRAINER OF INLET PUMP AC-ACR
200127	PVC HOSE D.35
200129	HOSE 5X11 FOR PRESSURE SWITCH
200410	DRAIN OUTL.WASH.1 1/2"65X47X2
200412	GASKET DRAIN 11/2" 45X33X3
200415	AIR TRAP GASKET -F2 18,5X10X3
200814	O-RING 34,52X41,58X3,53
200906	GASKET D.92X66X2
250806	TANK FILL HOSE CLAMP - AC/ACR
260407	STAINLESS STEEL NUTS D10 UNI 5
270101	HEXAGON LOCK NUT 1/2"
270104	LOCK NUT 1" 1/2
270107	BRASS LOCK NUT 3/8" FL803
270407	TANK DRAIN OUTLET ACR
290217	HOSE CLAMP ELBOW 12X3/8" TYPE
321098	SUPPORT
330526	FILTERS 22X28 SOLENOID V.MANIF
330584	WASH FILTER ACR
330585	PREWASH DRAWER FILTER AC-ACR
380830	AIR TRAP ST/ST FOR AC-ACR-GMC
450125	ELASTIC CLAMP D. 10,4X9,8
450515	STAINL.ST.SHIELD FOR 1 THERMOS
450911	DIGITAL THERMOSTAT MTR10P 24/5
460501	GASKET 24X17X2
510285	SOLENOID VALVE MANIFOLD - BRAS
620121	TWIN SOLENOID VALVE MANIFOLD

## 12 - Wash Tank Components 900mm

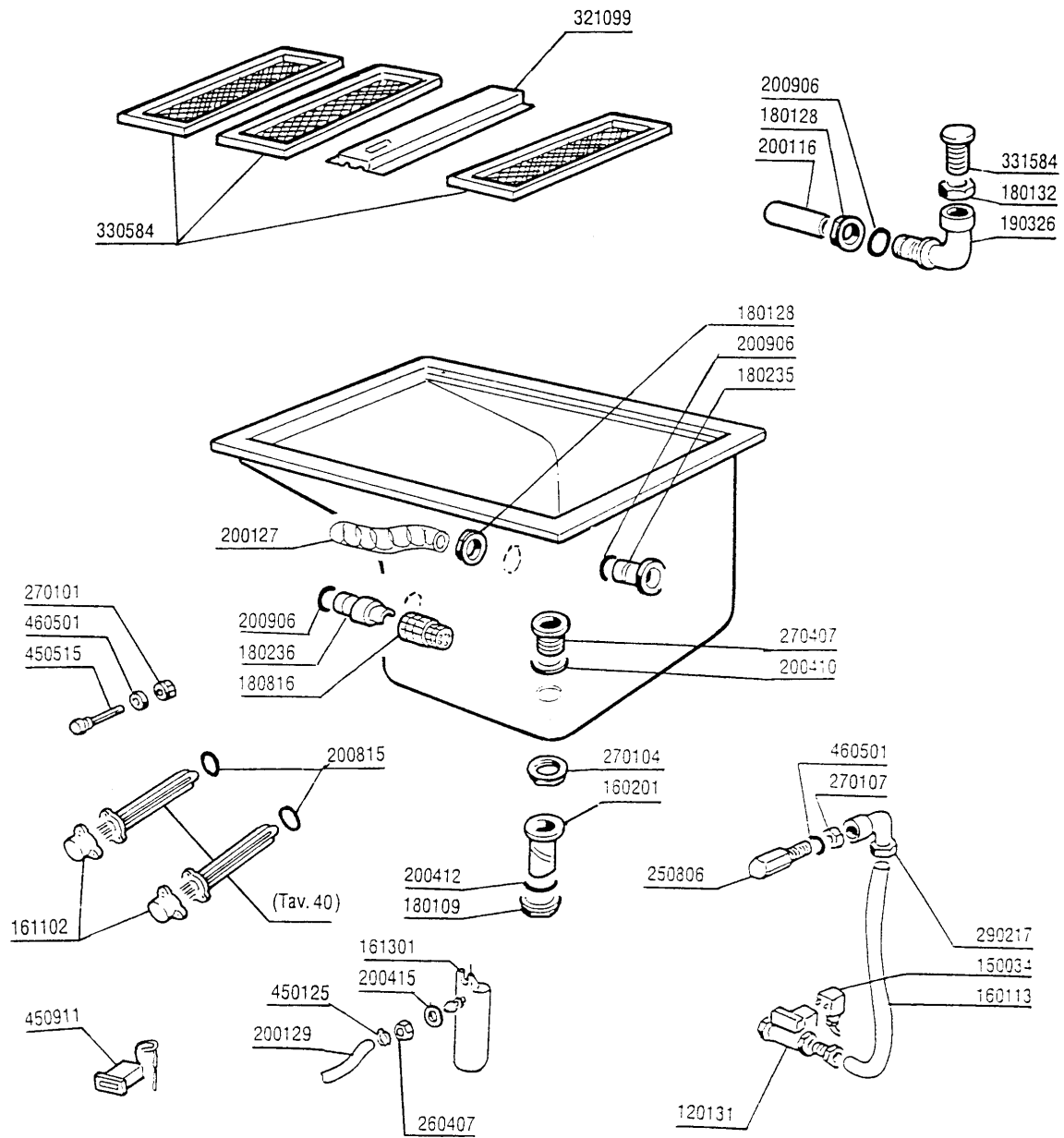

## 12 - Wash Tank Components 900mm

CODE	DESCRIPTION
120131	SOLEN. L182Q31-ZB10A 1/2"24V
150034	CONNEC.F.SOLEN.VALVE 122.09.N
160113	TUBE IN POL. RETIC. 12 EST
160201	ELBOW F.TANK INLET MOPLN
161102	ELEMENT COVER MOPL.
161301	AIR TRAP F2 C34-F45
180109	LOCK NUT 1 1/2"
180128	RING NUT 65,4 C140 C85
180132	LOCK NUT 2" FOR OVERFLOW AC-AC
180235	PUMP SUCTION C85-140
180236	PUMP SUCTION FOR AC-ACR-C155
180816	STRAINER OF INLET PUMP AC-ACR
190326	ELBOW FOR OVERFLOW AC-ACR
200116	RUBBER HOSE 60X70
200127	PVC HOSE D.35
200129	HOSE 5X11 FOR PRESSURE SWITCH
200410	DRAIN OUTL.WASH.1 1/2"65X47X2
200412	GASKET DRAIN 1 1/2" 45X33X3
200415	AIR TRAP GASKET -F2 18,5X10X3
200815	O-RING F. HEAT.ELEM.
200906	GASKET D.92X66X2
250806	TANK FILL HOSE CLAMP - AC/ACR
260407	STAINLESS STEEL NUTS D10 UNI 5
270101	HEXAGON LOCK NUT 1/2"
270104	LOCK NUT 1" 1/2
270107	BRASS LOCK NUT 3/8" FL803
270407	TANK DRAIN OUTLET ACR
290217	HOSE CLAMP ELBOW 12X3/8" TYPE
321099	SUPPORT
330584	WASH FILTER ACR
331584	ELBOW FOR AC-ACR OVERFLOW
450125	ELASTIC CLAMP D. 10,4X9,8
450515	STAINL.ST.SHIELD FOR 1 THERMOS
450911	DIGITAL THERMOSTAT MTR10P 24/5
460501	GASKET 24X17X2

13 - Wash Tank Components 900mm

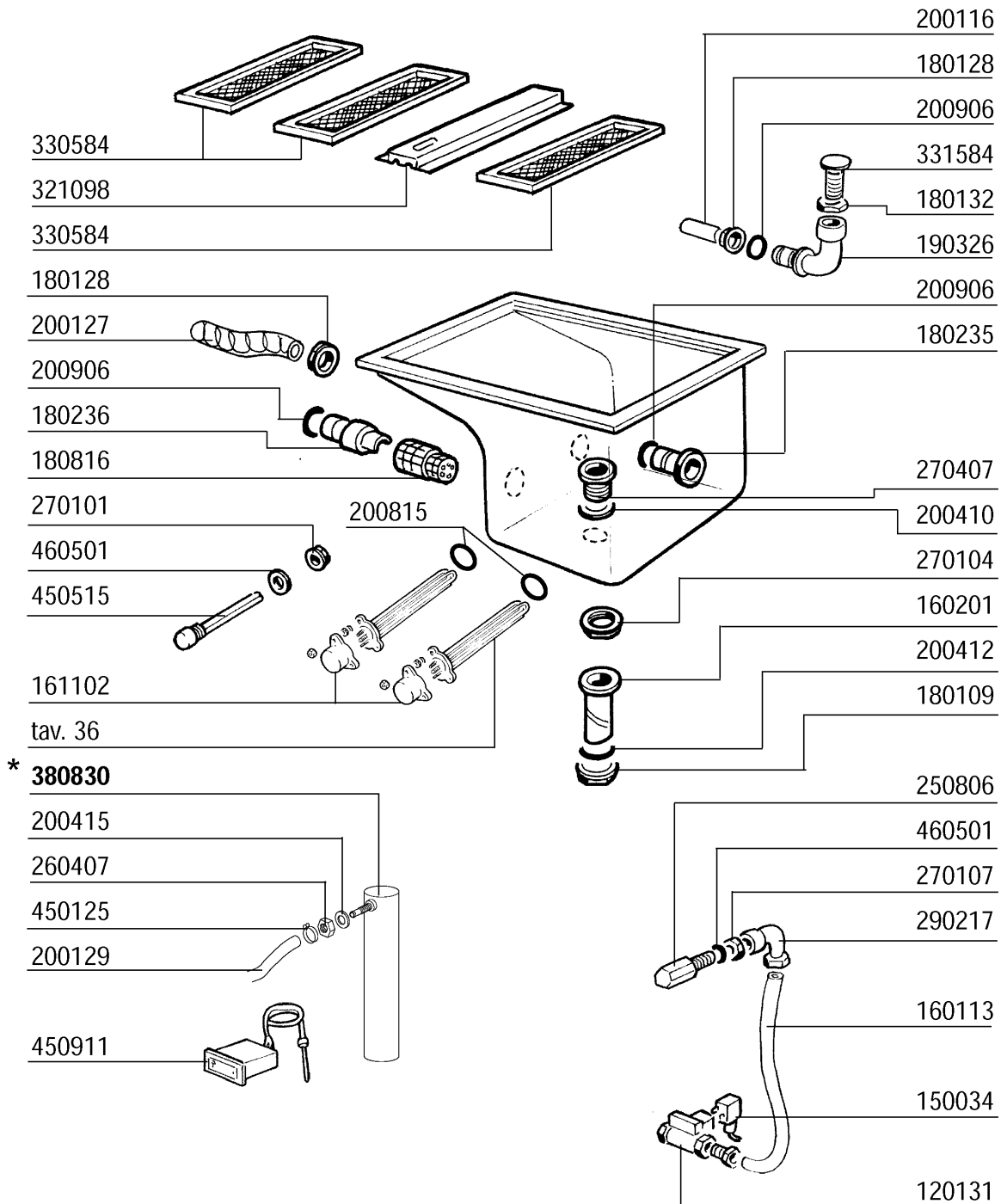

01 - 2002 S. AG.

\* Dalla matricola:  
\* A partir da la matr.  
\* From serial no.  
\* Ab Seriennr.  
\* Despues la matr.

**94865/94**

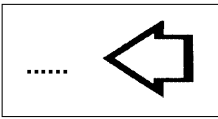

### 13 - Wash Tank Components 900mm

CODE	DESCRIPTION
120131	SOLEN. L182Q31-ZB10A 1/2"24V
150034	CONNEX.F.SOLEN.VALVE 122.09.N
160113	TUBE IN POL. RETIC. 12 EST
160201	ELBOW F.TANK INLET MOPLN
161102	ELEMENT COVER MOPL.
180109	LOCK NUT 1 1/2"
180128	RING NUT 65,4 C140 C85
180132	LOCK NUT 2" FOR OVERFLOW AC-AC
180235	PUMP SUCTION C85-140
180236	PUMP SUCTION FOR AC-ACR-C155
180816	STRAINER OF INLET PUMP AC-ACR
190326	ELBOW FOR OVERFLOW AC-ACR
200116	RUBBER HOSE 60X70
200127	PVC HOSE D.35
200129	HOSE 5X11 FOR PRESSURE SWITCH
200410	DRAIN OUTL.WASH.1 1/2"65X47X2
200412	GASKET DRAIN 1 1/2" 45X33X3
200415	AIR TRAP GASKET -F2 18,5X10X3
200815	O-RING F. HEAT.ELEM.
200906	GASKET D.92X66X2
250806	TANK FILL HOSE CLAMP - AC/ACR
260407	STAINLESS STEEL NUTS D10 UNI 5
270101	HEXAGON LOCK NUT 1/2"
270104	LOCK NUT 1" 1/2
270107	BRASS LOCK NUT 3/8" FL803
270407	TANK DRAIN OUTLET ACR
290217	HOSE CLAMP ELBOW 12X3/8" TYPE
321098	SUPPORT
330584	WASH FILTER ACR
331584	ELBOW FOR AC-ACR OVERFLOW
380830	AIR TRAP ST/ST FOR AC-ACR-GMC
450125	ELASTIC CLAMP D. 10,4X9,8
450515	STAINL.ST.SHIELD FOR 1 THERMOS
450911	DIGITAL THERMOSTAT MTR10P 24/5
460501	GASKET 24X17X2



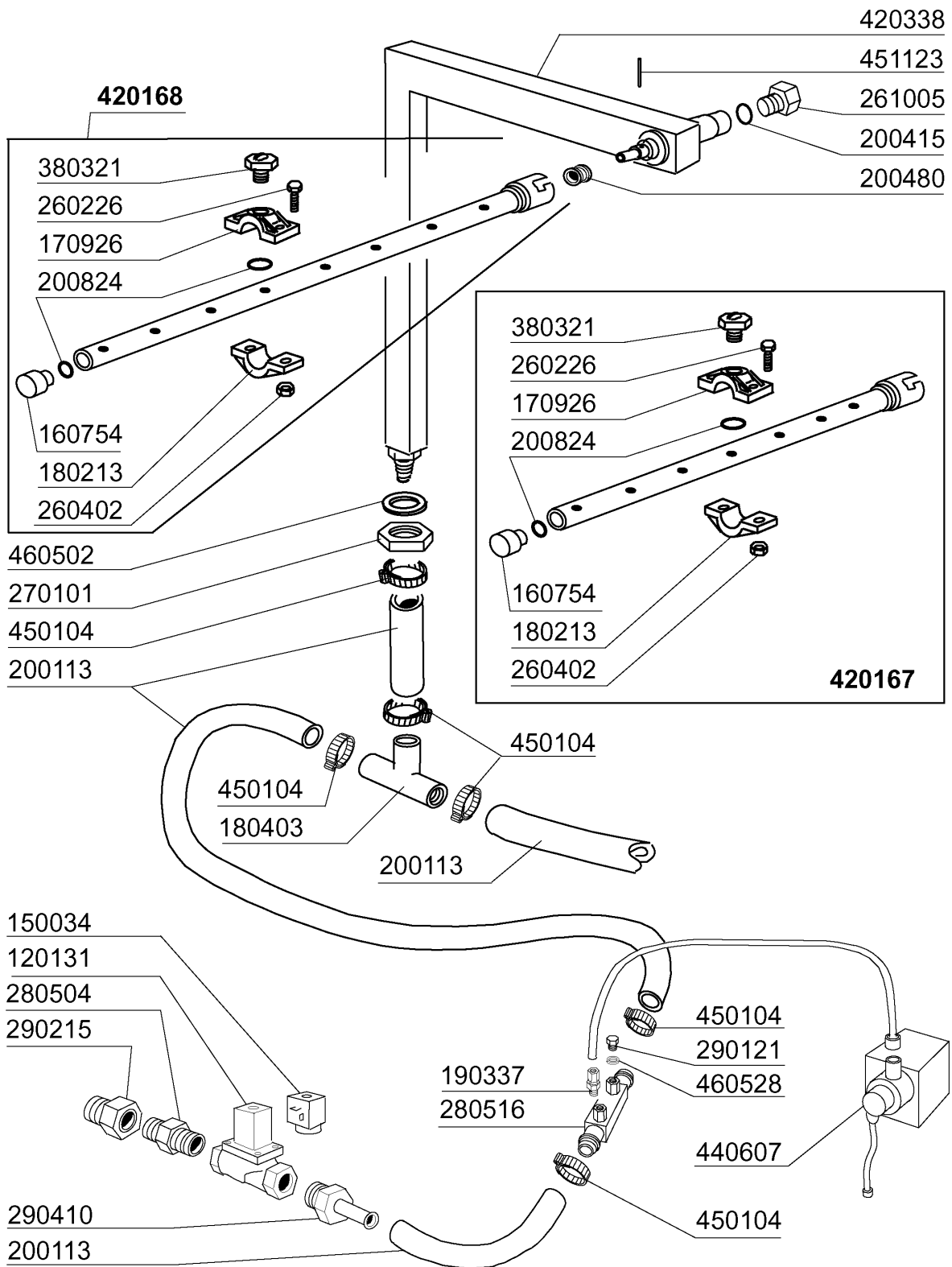

06 - 2001 S.A.G.

## 14 - Sanitizing system

CODE	DESCRIPTION
120131	SOLEN. L182Q31-ZB10A 1/2"24V
150034	CONNEC.F.SOLEN.VALVE 122.09.N
160754	PLUG FOR RINSE ARMS SE NE
170926	RINSE JET HOLDER S-SE-NE
180213	FLANGE F.JET LOCKING F2-C34
180403	TEE-NIPPLE F2-F300-B10-11
190337	CONNECTION 1/4" X 1/8"
200113	RUBBER HOSE 12 X 22
200415	AIR TRAP GASKET -F2 18,5X10X3
200480	GASKET F. RINSE CONNECT.
200824	O-RING 1,78X12,42X15,98
260226	STAINL.ST TCP SCREW 4X12 A2 UN
260402	STAINLESS STEEL NUT D4 UNI 55
261005	SCREW F. TEE UP.WASH F2-B41
270101	HEXAGON LOCK NUT 1/2"
280504	MANIFOLD CONN.HOSE
280516	CONNECTION 14M X 2
290121	BRASS PLUG 1/8"
290215	1/2"BSP M/F UNION BRASS
290410	NIPPLE 1/2"
380321	RINSE JETS OV 1/8" 303 40LT 80
420167	WASH ARM FOR SELF CLEANING
420168	WASH ARM FOR SELF CLEANING
420338	SELFCLEANING RAMP NE
440607	INJECTOR 24V 50HZ
450104	CLAMP FE ZN H=12,5 15-24
451123	ELASTIC PIN 4X16
460502	GASKET 30X21X2
460528	GASKET 15X10X2 FOR RINSE NIPPE

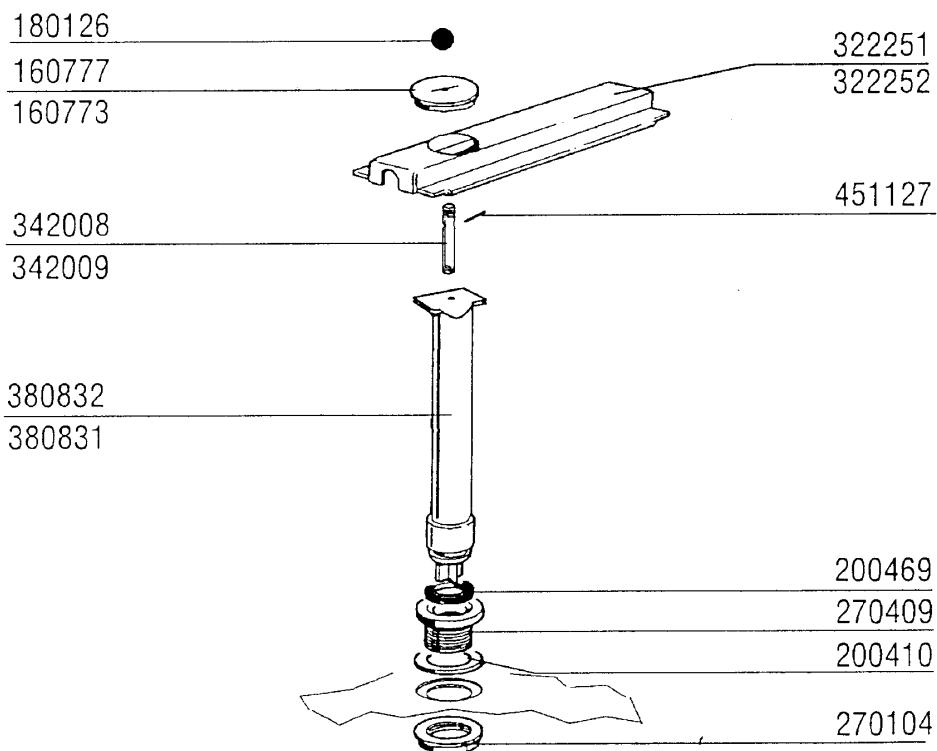
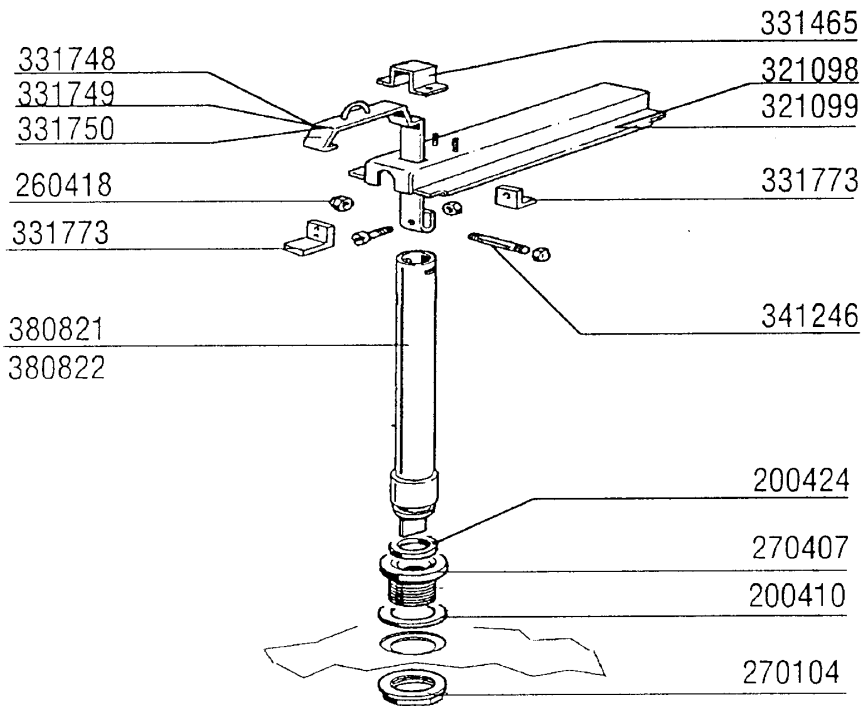

01-96

15 - Drain Parts

CODE	DESCRIPTION
160773	PLUG FOR OVERFLOW PIPE
160777	OVERFLOW PIPE PLUG PREWASH AC-
180126	HANDLE F.OVERFLOW PIPE SNL
200410	DRAIN OUTL.WASH.1 1/2"65X47X2
200424	O RINGS WASH/PRE-WASH ARMS
200469	STAND PIPE O RING 45X35,5X7
260418	SELF-LOCKING NUT M4
270104	LOCK NUT 1" 1/2
270407	TANK DRAIN OUTLET ACR
270409	DRAIN OUTLET AC-ACR
321098	SUPPORT
321099	SUPPORT
322251	SUPPORT
322252	SUPPORT
331465	BRACKET FOR UNLOADING
331748	PREWASH OVERFLOW LEVER FOR AC-
331749	WASH OVERFLOW LEVER FOR AC-ACR
331750	WASH OVERFLOW LEVER-ACR CORNER
331773	BRACKET
341246	SHAFT FOR AC-ACR OVERFLOW
342008	OVERFLOW SPACER PREWASH TANK A
342009	OVERFLOW SPACER WASH TANK AC-A
380821	OVERFLOW PIPE WASH TANK ACR
380822	OVERFLOW PIPE PREWASH TANK ACR
380831	OVERFLOW PIPE PREWASH TANK AC-
380832	OVERFLOW PIPE WASH TANK AC-ACR
451127	ELASTIC PIN 5X34

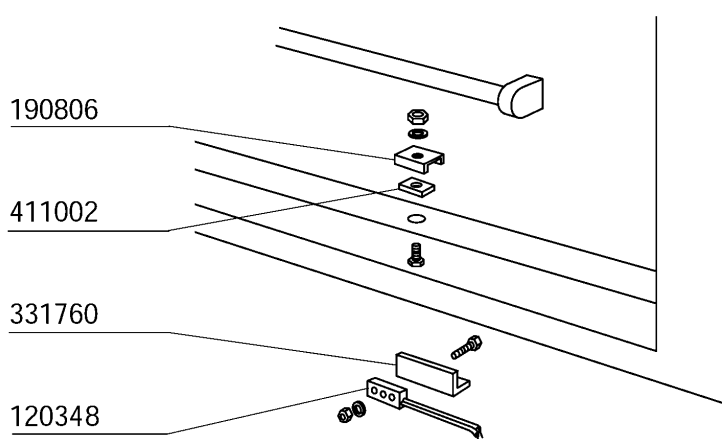
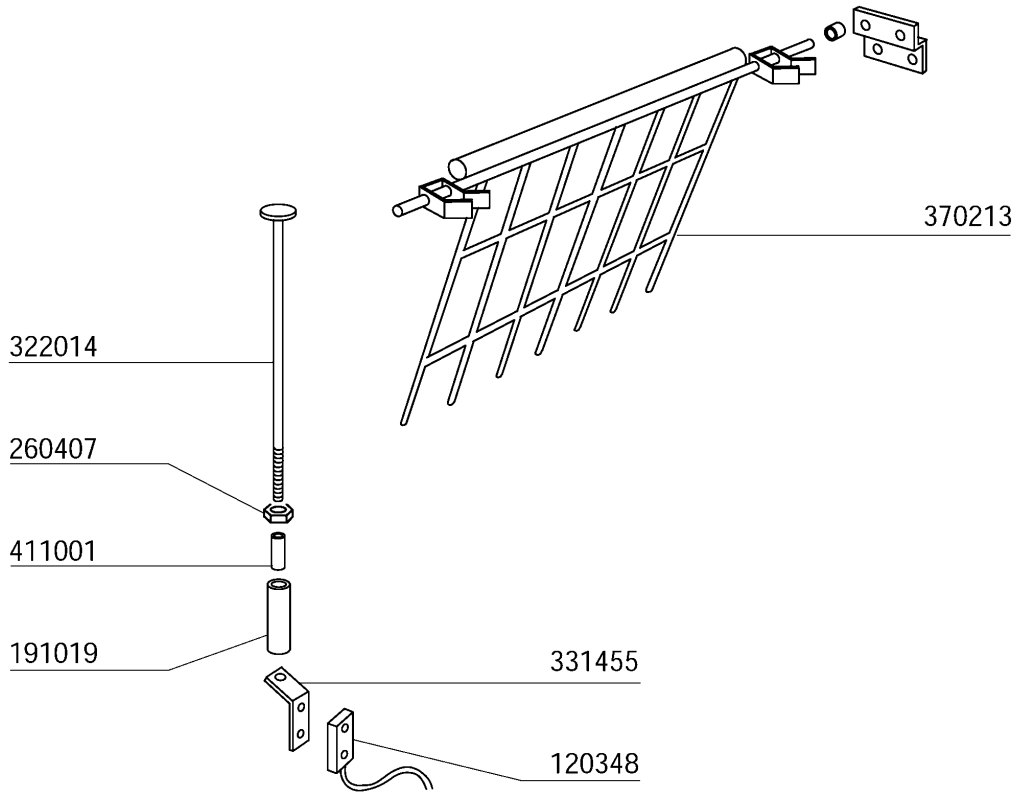

1 - 12 - 2000 01

## 16 - Micro switches/Economiser

<b>CODE</b>	<b>DESCRIPTION</b>
120348	MAGN.SWITCH (N.O.)
190806	MAGNET HOUSING
191019	MAGNET HOUSING S90 MOPL.-S.N.L
260407	STAINLESS STEEL NUTS D10 UNI 5
322014	LEVER
331455	BRACKET FOR RINSE MICROSWITCH
331760	BRACKET
370213	RINSE ECONOMISER
411001	PERMANENT MAGNET 8X40
411002	PERMANENT MAGNET 24X12

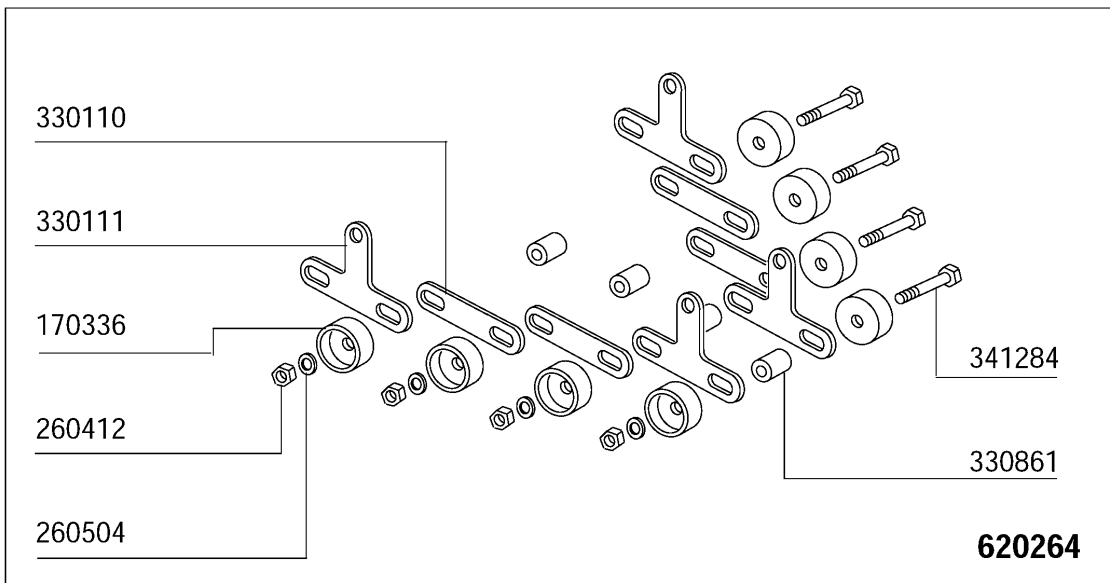
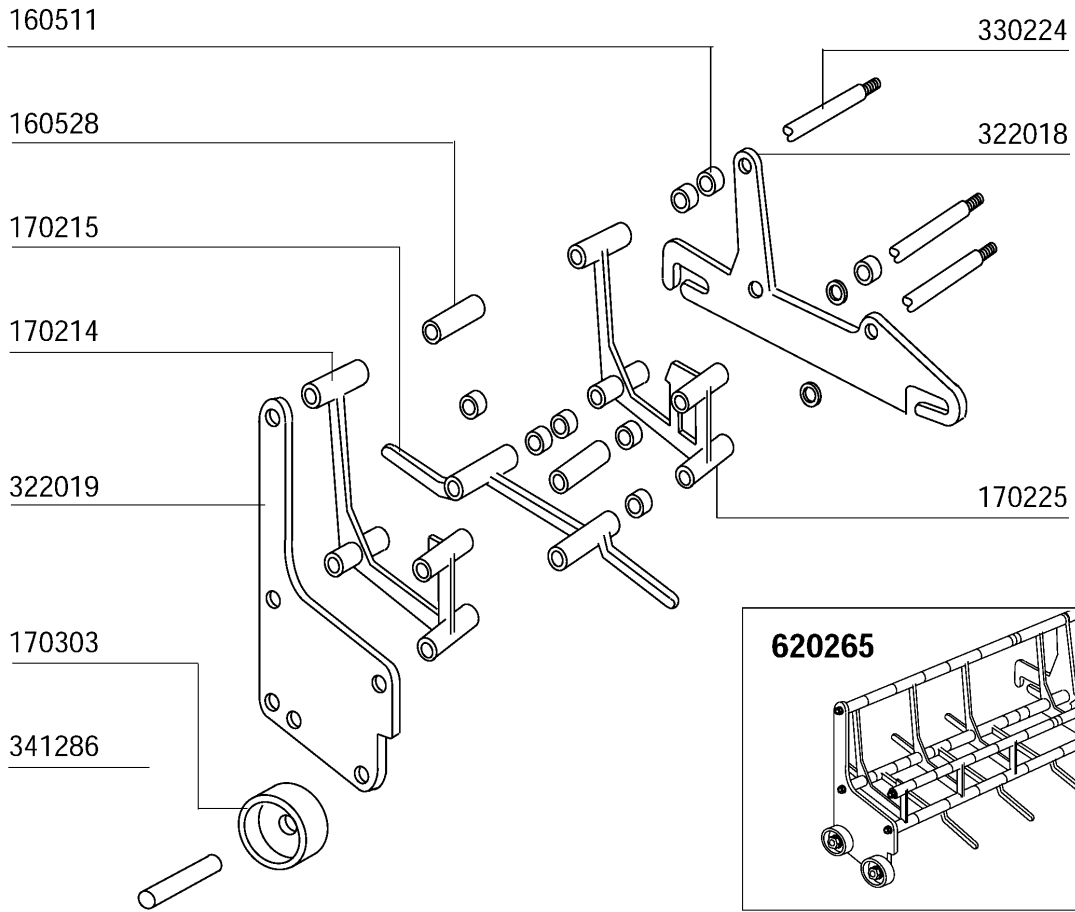

1 - 4 - 95

## 17 - Drive unit

CODE	DESCRIPTION
160511	SPACER 7,93 MOP
160528	SPACER 32MM
170214	FINGER FOR GMC CONVEYOR
170215	SPACER FOR GMC CONVEYOR
170225	PEG FOR CARRIER GMC
170303	WHEEL D.32
170336	WHEEL FOR GMC CHAIN
260412	SELF-LOCKING NUT M6
260504	ST/ST FLAT WASHER D6
322018	CENTRAL SUPPORT
322019	SUPPORT
330110	SHACKLES FOR GMC CHAIN
330111	ST/ST FINGER FOR GMC CHAIN
330224	TIE ROD FOR GMC CHAINE
330861	BUSH
341284	PIN FOR GMC CHAIN
341286	PIN FOR GMC WHEEL
620264	GMC CHAIN (1.092MT)
620265	GMC BASKET P=156MM



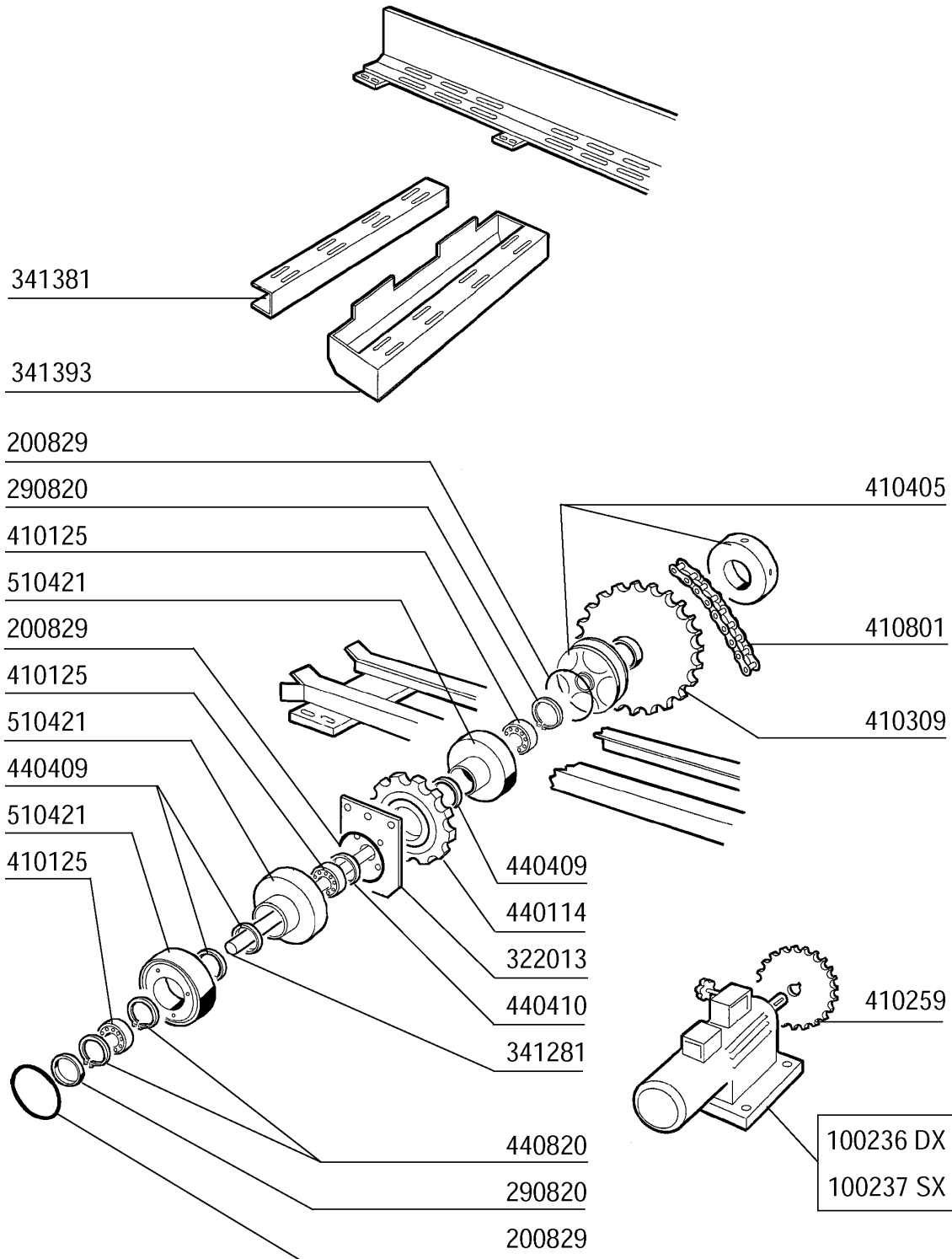

02 - 97

## 18 - Drive unit

CODE	DESCRIPTION
100236	VARIABLE DRIVE MOTOR 220/380
100237	VARIABLE MOTOR DRIVE 220/380 T
200829	O-RING 81,92X92,58X5,33
290820	DISTANCE PIECE FOR DRIVE
322013	SUPPORT
341281	PIN FOR GMC CHAIN
341381	SUPPORT
341393	SUPPORT
410125	BALL BEARING 25X47X12 - 6005
410259	PINION Z16 D.32 1/2
410309	CROWN DISCS 38T 1/2PITCH
410405	TORQUE LIMITER D.25 NTP SE/1
410801	DRIVE CHAIN 1/2" N-S
440114	DRIVE WHEEL FOR GMC (BRASS)
440409	SEAL RING MIM 25X40X7
440410	SEAL MIM 25X52X7
440820	SNAP RING D.25 DIN 471
510421	DRIVE AXLE SUPPORT FOR GMC

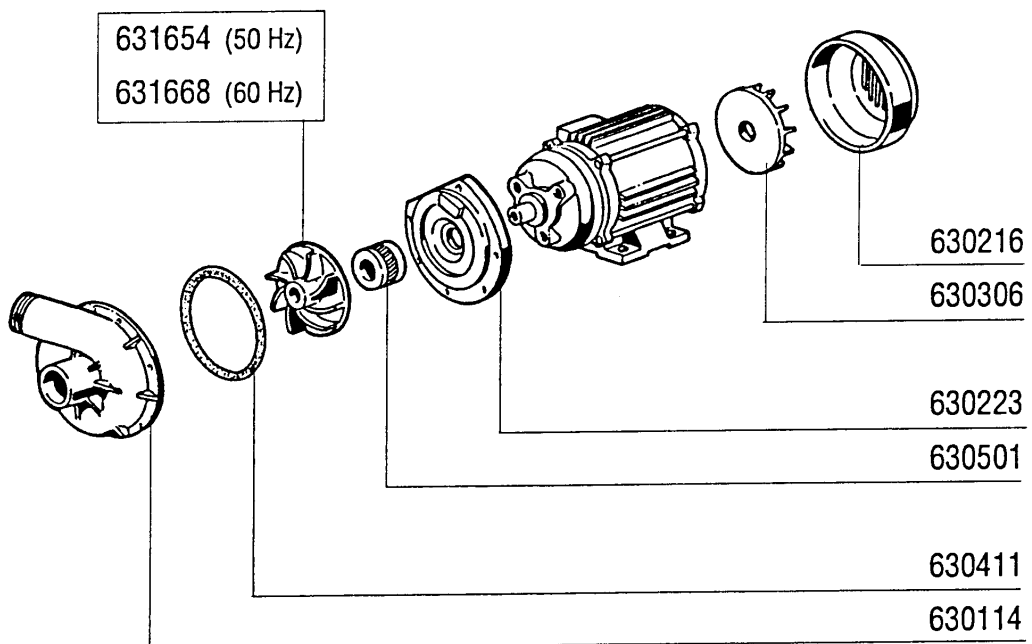
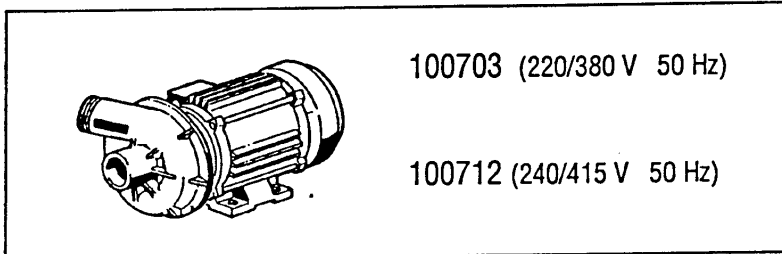

1 - 4 - 95

## 19 - Prewash pump 600mm

<b>CODE</b>	<b>DESCRIPTION</b>
100703	PUMP 1,5HP 220/380 50HZ 1241
100712	PUMP 1,5HP 240/415 1241
630114	VOLUTE FI HP2-2,7-3-3,2
630216	FAN HOUSING FIR HP 2-3
630223	BACK PLATE PUMP HP2-3-3,2
630306	PUMP FAN IMPELLOR FI HP.2-3
630411	O-RING PUMP FI HP 2-2,7
630501	SEAL FOR PUMP HP 2-3-3,2
631654	PUMP IMPELLER 1,5HP 50HZ 1241
631668	IMPELLER D.85 HP1,5-60HZ-1241

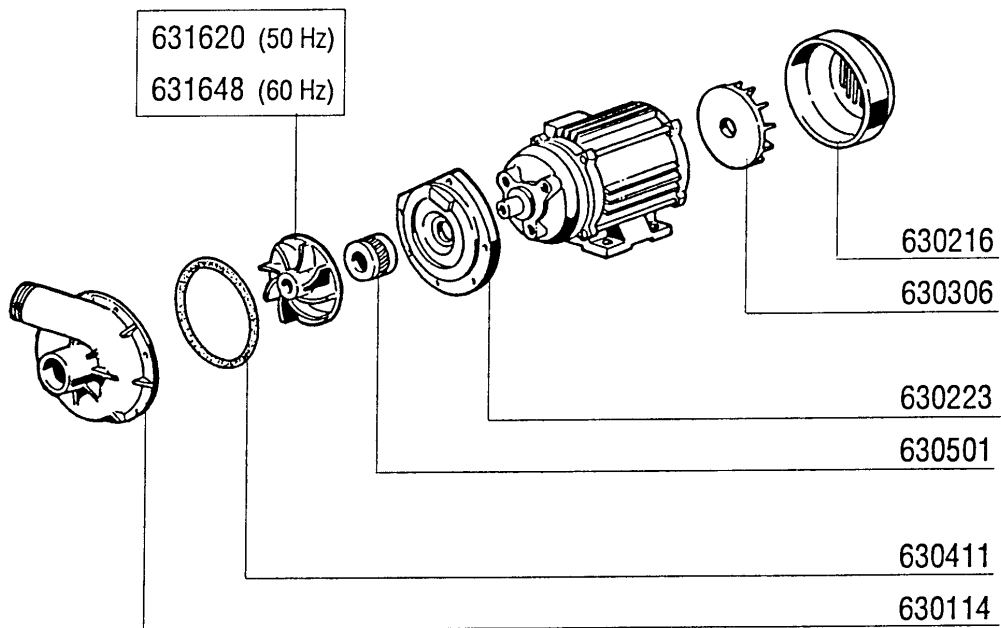
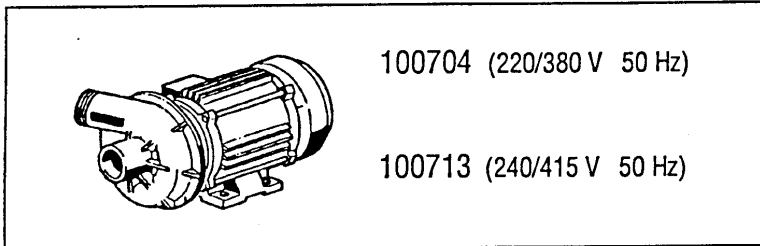

20 - Wash pump 900mm

CODE	DESCRIPTION
100704	PUMP HP 3,5 220/380 50HZ 1244
100713	PUMP 3,5HP 240/415 50HZ ACR
630114	VOLUTE FI HP2-2,7-3-3,2
630216	FAN HOUSING FIR HP 2-3
630223	BACK PLATE PUMP HP2-3-3,2
630306	PUMP FAN IMPELLOR FI HP.2-3
630411	O-RING PUMP FI HP 2-2,7
630501	SEAL FOR PUMP HP 2-3-3,2
631620	IMPELLER HP 3-3,2 1205-43
631648	IMPELLER 1243 HP3,2 60HZ D.110

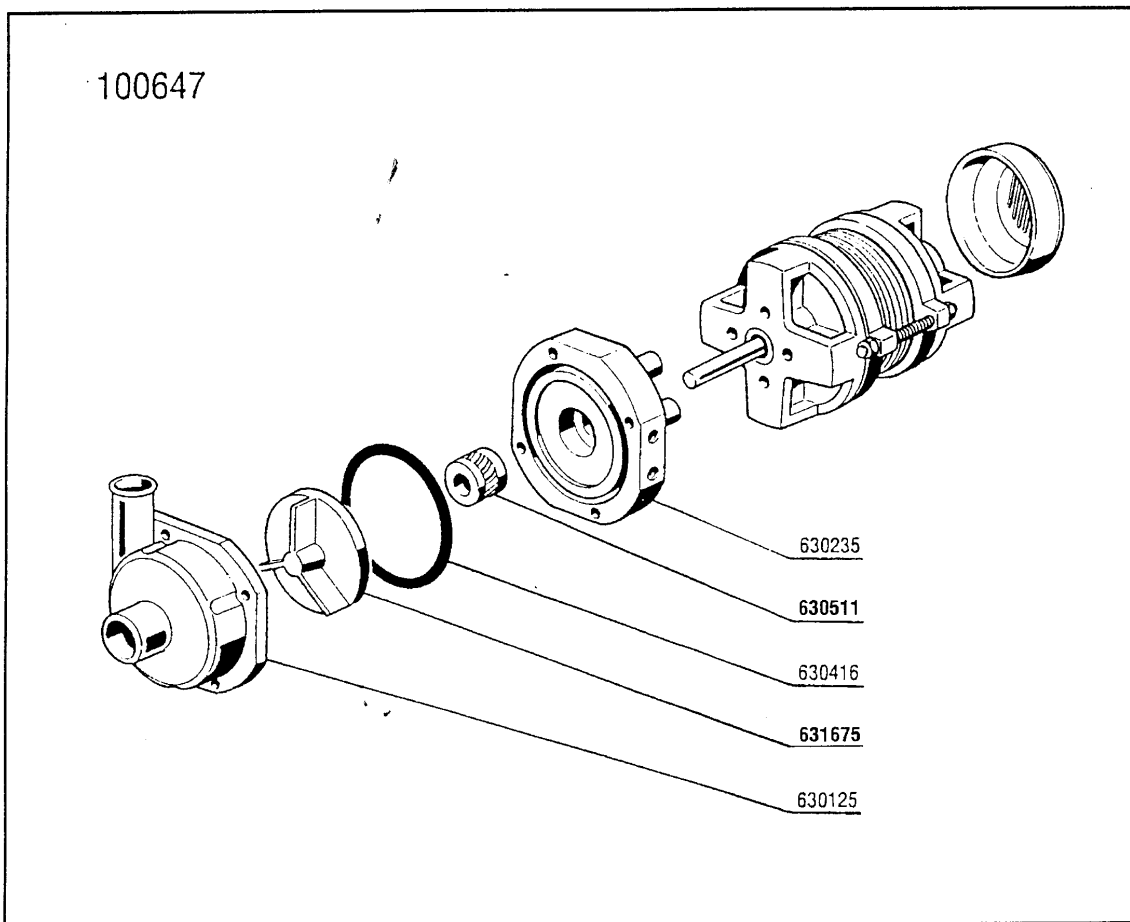

## 21 - Ecorinse Pump

CODE	DESCRIPTION
100647	PUMP HP 0,20 220/240/3 4226
630125	VOLUTE 0,12/0,3(2212-29)
630235	PUMP COVER 0,12/0,3 2212-19
630416	OR FOR VOLUTE 0,12/0,3
630511	PUMP SEAL HP 0,10 82
631675	ST/ST PUMP IMPELLER 0,2HP 2226



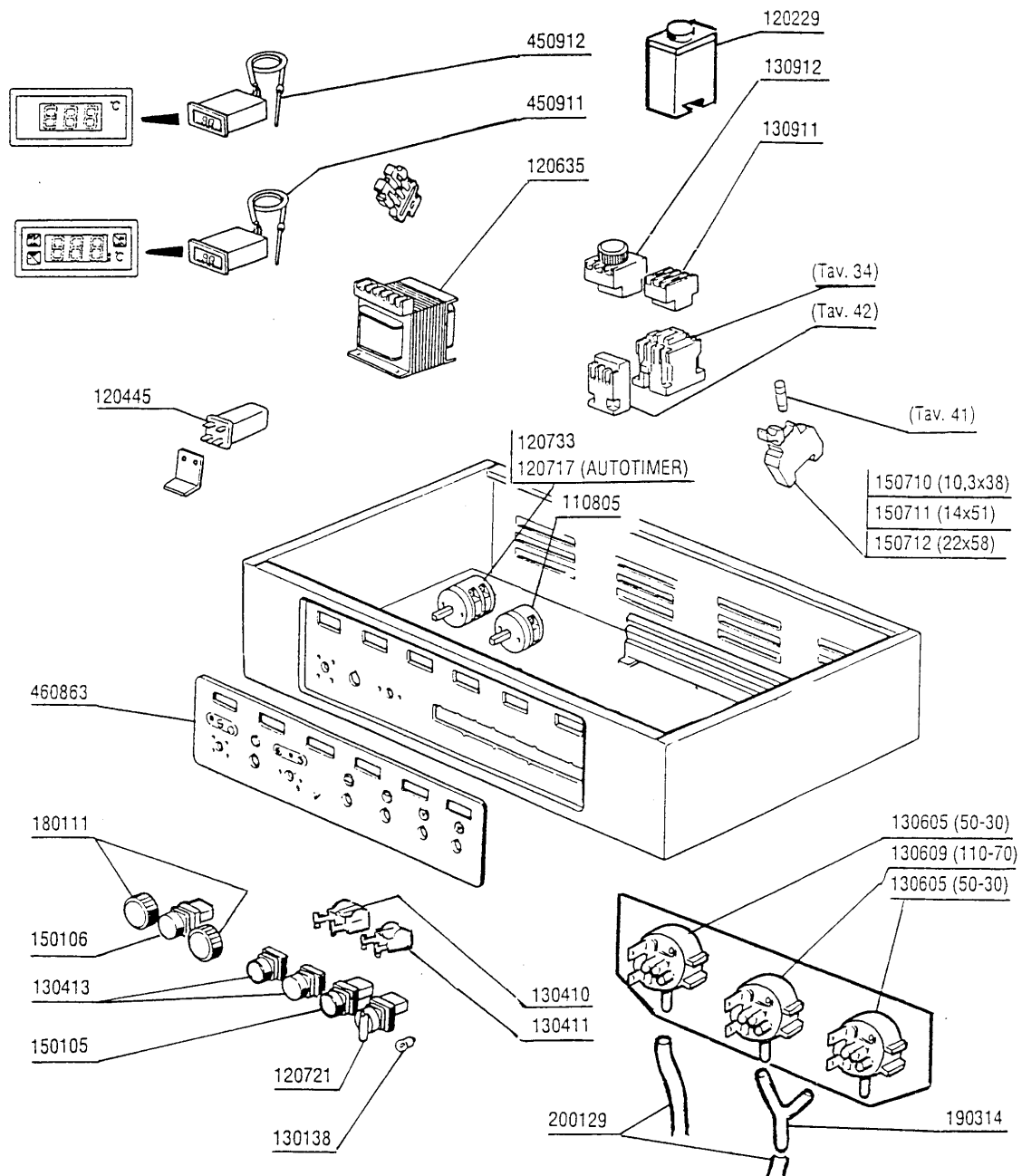

## 22 - Control Box

CODE	DESCRIPTION
110805	SWITCH THREEPOLE
120229	ELECTR.TIMER 24V AUTOTIMER S-S
120445	AUXILIARY RELAY S.B2/3 24V
120635	TRANSFORMER 400VA220-240-380-4
120717	SWITCH 25 AMP FIVE-POLE S-SE A
120721	SELECT.SWITCHRM300N-SHORT KNOB
120733	4-POLE SWITCH 25A 500V
130138	LIGHT WITH BAYONET COUPLING 3W
130410	STOP CONTACT F40 CN RED
130411	START CONTACT YELLOW
130413	GREEN PUSH BUTTON
130605	PRESSURE SWITCH 50-30 1 LEVEL
130609	1 LEVEL PRESSURE SWITCH 110-70
130911	CONTACT LA1 D40 A65
130912	TIMER CONTACT 0,1/30SEC. LA3D2
150105	LAMP RED D.22X5
150106	LAMP GREEN 22X5
150710	FUSE CARRIER 10,3X38 ART.21401
150711	FUSE CARRIER 14X51 ART.21501
150712	FUSE CARRIER 22X58 ART.21601
180111	BLACK KNOB
190314	Y-NIPPLE OF PRESS.SWITCH N 2S
200129	HOSE 5X11 FOR PRESSURE SWITCH
450911	DIGITAL THERMOSTAT MTR10P 24/5
450912	DIGIT.THERMOMETER MT10P V24/50
460863	PANEL (460865)

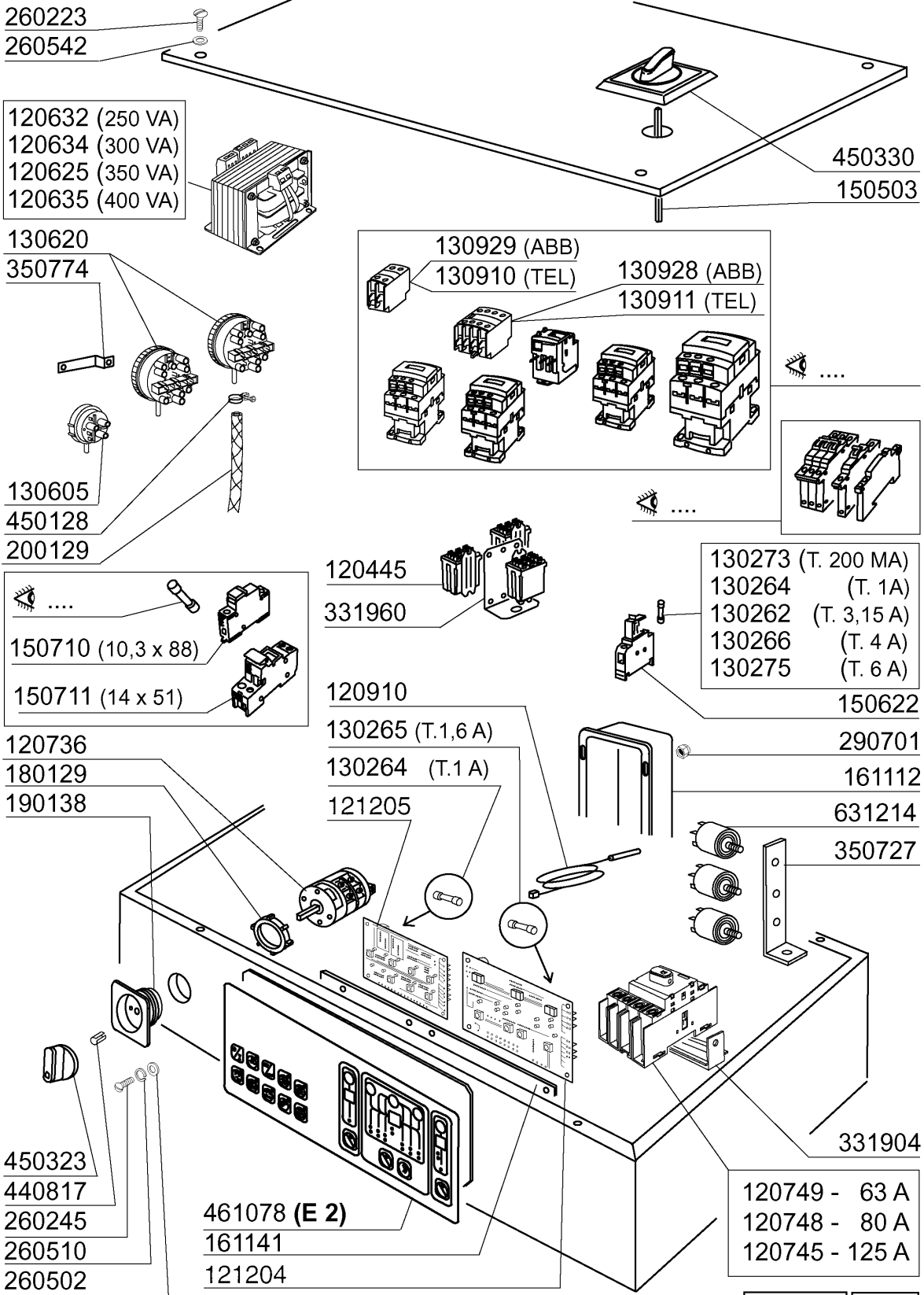

01 - 2002 | S. AG.

23 - Control Box -E2-

CODE	DESCRIPTION
120445	AUXILIARY RELAY S.B2/3 24V
120625	TRANSFOR.350VA 225*415/12V-24V
120632	TRANSFORMER 250VA220-240-380-4
120634	TRANSFORMER 300VA220-240-380-4
120635	TRANSFORMER 400VA220-240-380-4
120736	4 POLE MAIN SWITCH 25A 500V
120745	MAIN SWITCH 4 POLE 125A
120748	MAINSWITCH 80A 4P
120749	MAINSWITCH 63A 4P
120910	ELECTRONIC TOUCH PAD CONTROLS
121204	ELECTRONIC PANEL THERMOREG.7+1
121205	"ELECTRONIC 2" PANEL
130262	FUSE 5X20 T315MA
130264	FUSE 5X20 1A
130265	FUSE 5X20 1,6A
130266	FUSE 5X20 4A
130273	FUSE 5X20 250MA GLAS
130275	FUSE 5X20 6,3A GLAS
130605	PRESSURE SWITCH 50-30 1 LEVEL
130620	PRESSURE SWITCH 3 LEVEL 50-30/
130910	CONTACT LA1 D20 A65
130911	CONTACT LA1 D40 A65
130928	CONTACT ABB 4NO
130929	CONTACT ABB 1NO/1NC 30"
150503	EXTENTION FOR MAIN SWITCH
150622	FUSE HOLDER SIEMENS 1,5MM-6,3A
150710	FUSE CARRIER 10,3X38 ART.21401
150711	FUSE CARRIER 14X51 ART.21501
161112	BACK COVER CHANNEL 300 S N
161141	PROTECTION
180129	NUT FOR MAIN SWITCH SUPPORT
190138	SUPPORT
200129	HOSE 5X11 FOR PRESSURE SWITCH
260223	M5X12 MSH/HD SCREW SPECIAL S/S
260245	SPECIAL SCREW TC 3,5X16
260502	S/S FLAT WASHER D.4
260510	GROWER WASHER D.4
260542	WASHER D.5
290701	HEXAGON BLIND NUTS GM H12
331904	BRACKET
331960	BRACKET
350727	BRACKET
350774	BRACKET
440817	SNAP RING LSCB/1853/17/00
450128	CLAMP
450323	KNOB FOR BC-BR-C95-C155
450330	KNOB FOR MAIN SWITCH
461078	PLATE "ELECTRONIC 2"
631214	ANTI-NOISE FILTER 4011135007 3

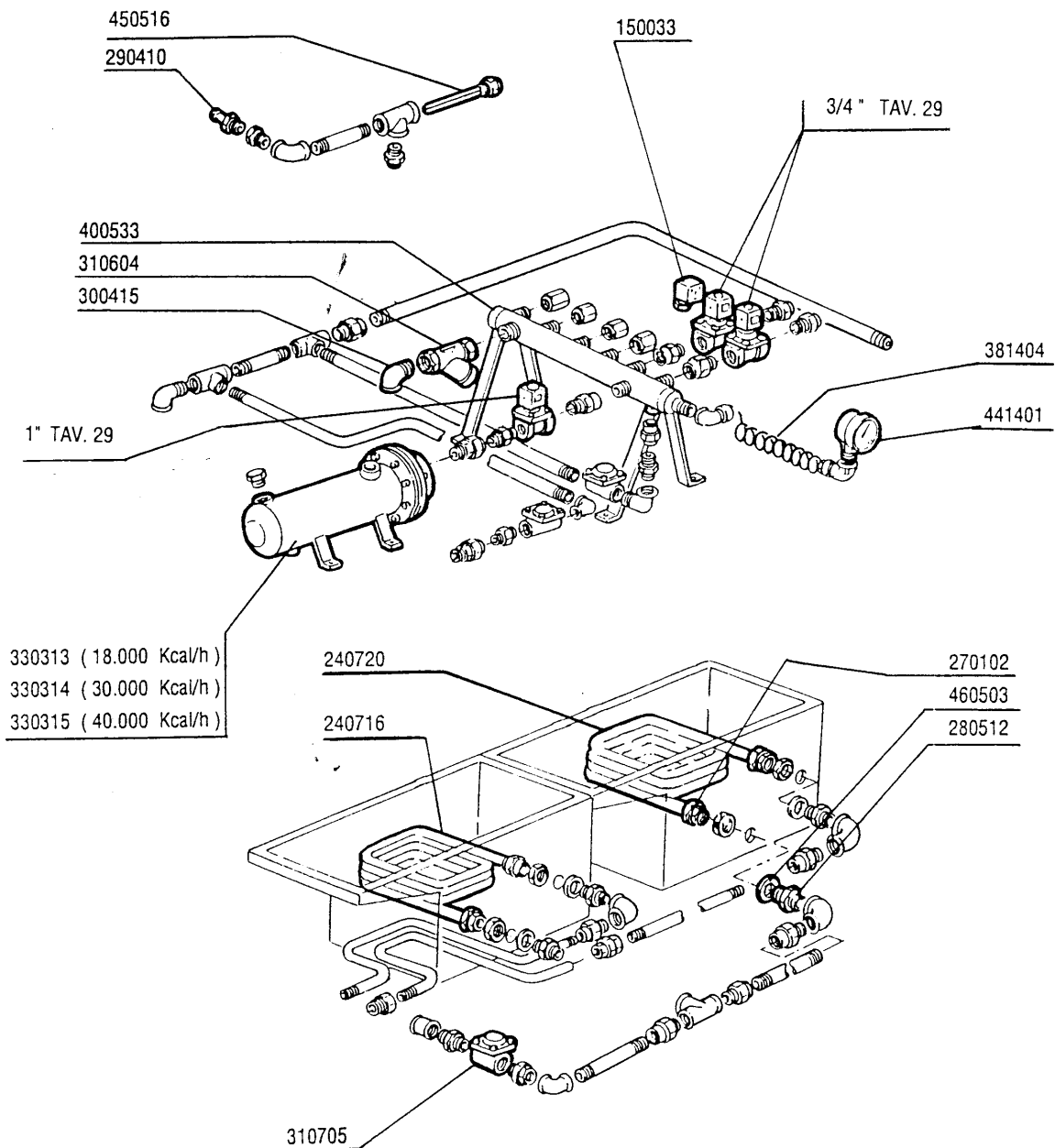

24 - Steam Version

CODE	DESCRIPTION
150033	CONNEX.F.SOLEN.VALVE 182.09.N
240716	STEAM COIL G66-S3
240720	S/S STEAM COIL 12.000KCAL ACR/
270102	LOCK NUT 3/4"
280512	STEAM COIL CONNECTION
290410	NIPPLE 1/2"
300415	ELL 2" MF
310604	STRAINERS JU 2" MOD.45
310705	STEAM TRAPS MK25/3 D.1/2"
330313	STEAM BOILER 18000KCAL/H
330314	STEAM BOILER 30000 KCAL/H
330315	STEAM BOILER 40000KCAL/H
381404	HOSE STEAM GAUGE
400533	ST/ST STEAM MANIFOLD FOR NE MA
441401	PRESSURE GAUGE 60 SCALO-4CR1/4
450516	THERMOSTAT SHIELD FOR 2 TERMOS
460503	SEALING WASHER 38X27X2(3/4)

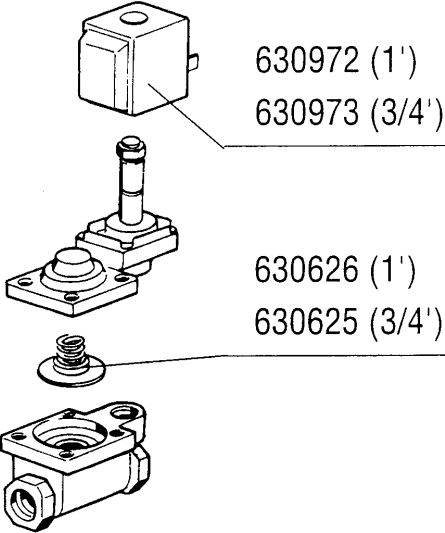
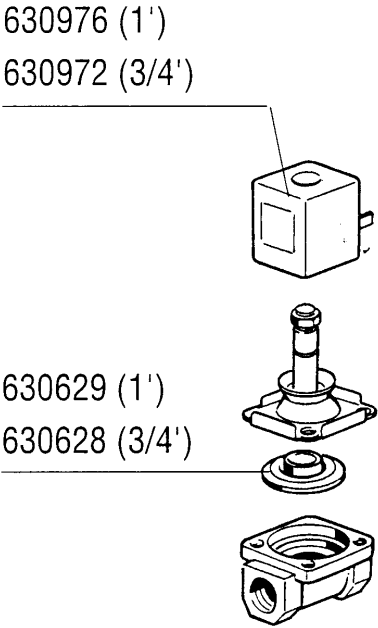
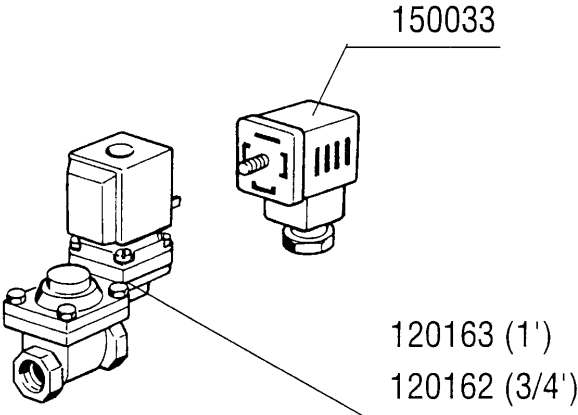
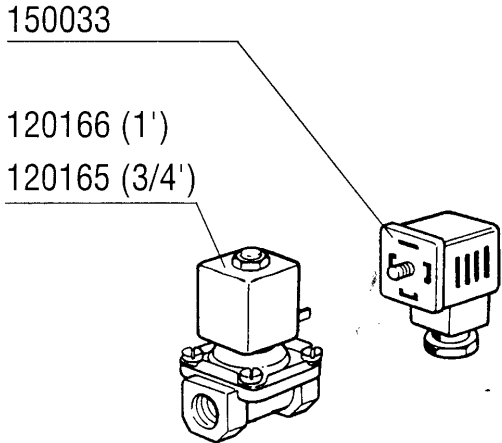

0 ÷ 2 bar

0,5 ÷ 2,5 bar

## 25 - Steam solenoid valve

CODE	DESCRIPTION
120162	SOLENOID VALVE L145R1Z734A 3/4
120163	SOLEN.VAL.ST.L145R1Z234A 1"24V
120165	SOLEN.VALVE ST.24V50HZ 3/4"
120166	STEAM SOLEN.VALVE 1" 24V-50
150033	CONNEC.F.SOLEN.VALVE 182.09.N
630625	KIT F.SOLEN.VALVE
630626	KIT FOR SOLENOID VALVE 145 1"
630628	KIT F.SOLEN.V.L153D1 3/4"
630629	KIT SOLENOID VALVE 1" STEAM L1
630972	COIL Z534A/V.24-L145A-3/4
630973	COIL Z614A/V.24-L145-3/4 A
630976	COIL Z114A/V24/50HZ L153-1"



26 - Steam Condenser

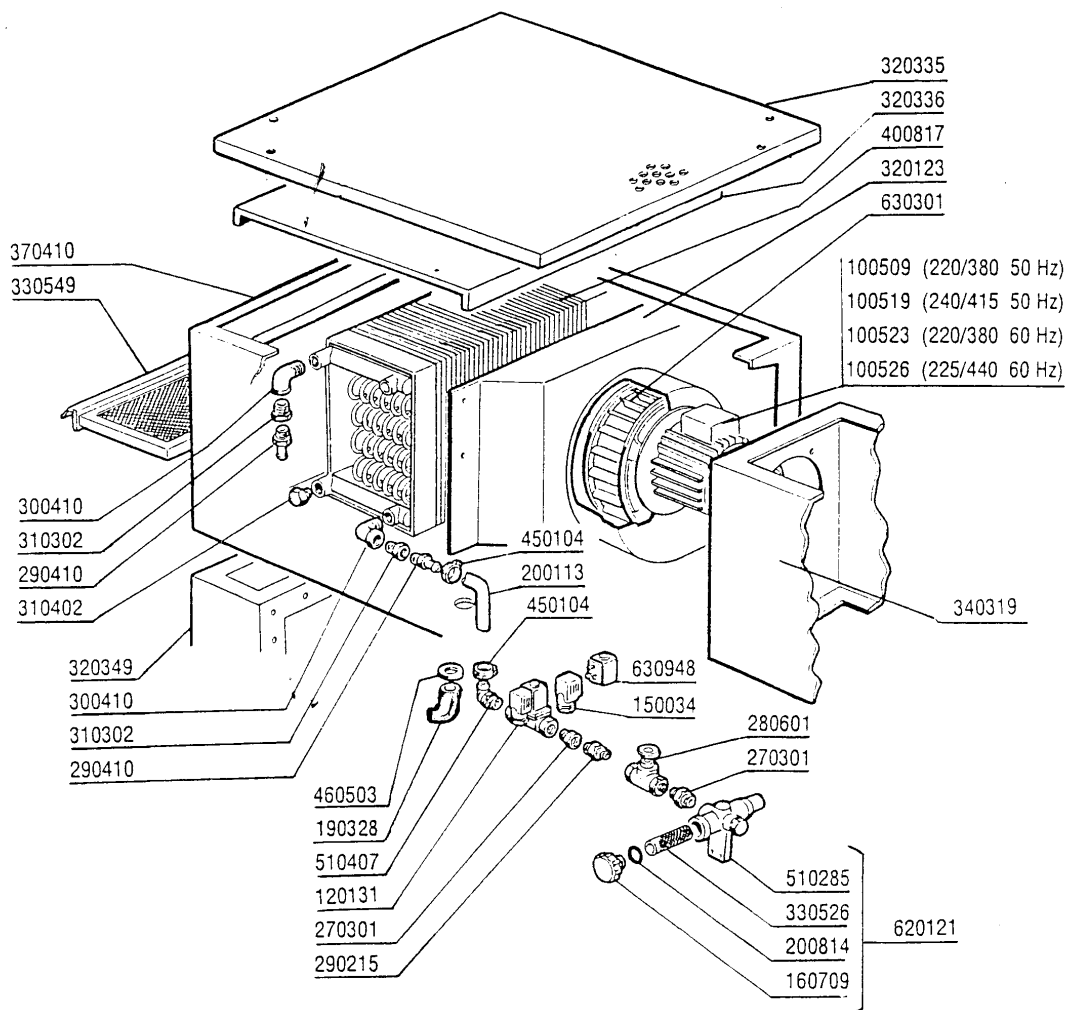

## 26 - Steam Condenser

CODE	DESCRIPTION
100509	FAN 0,75HP 220/415 V164/2
100519	FAN HP0,10 220/380 VR90CAT
100523	FAN 0,75 HP 220/380V-60HZ
100526	FAN HP 0,75 255/440-60-VR184
120131	SOLEN. L182Q31-ZB10A 1/2"24V
150034	CONNEX.F.SOLEN.VALVE 122.09.N
160709	KNOB OF MANIFOLD F. SOLEN. VAL
190328	DRAIN 3/4"
200113	RUBBER HOSE 12 X 22
200814	O-RING 34,52X41,58X3,53
270301	BRASS NIPPLES 1/2"
280601	GATE VALVE 1/2" BRASS
290215	1/2"BSP M/F UNION BRASS
290410	NIPPLE 1/2"
300410	ELL 3/4" MF
310302	NIPPLE 3/4"-1/2"
310402	PLUG 3/4"
320123	VORTEX BREAKER F.STEAM CONDENS
320335	TOP PANEL FOR STEAM CONDENSER
320336	TOP PANEL FOR STEAM CONDENSER
320349	TOP FOR SPLASH HOOD WITH STEAM
330526	FILTERS 22X28 SOLENOID V.MANIF
330549	CONDENSATE UNIT FILTER
340319	PANEL
370410	CONDENSER MODULE
400817	BATTERY FOR STEAM CONDENSER +
450104	CLAMP FE ZN H=12,5 15-24
460503	SEALING WASHER 38X27X2(3/4)
510285	SOLENOID VALVE MANIFOLD - BRAS
510407	NIPPLE FOR BOILER N S
620121	TWIN SOLENOID VALVE MANIFOLD
630301	FAN IMPELLOR FOR 100509
630948	COIL Z610A 24V 50/60-L180V01

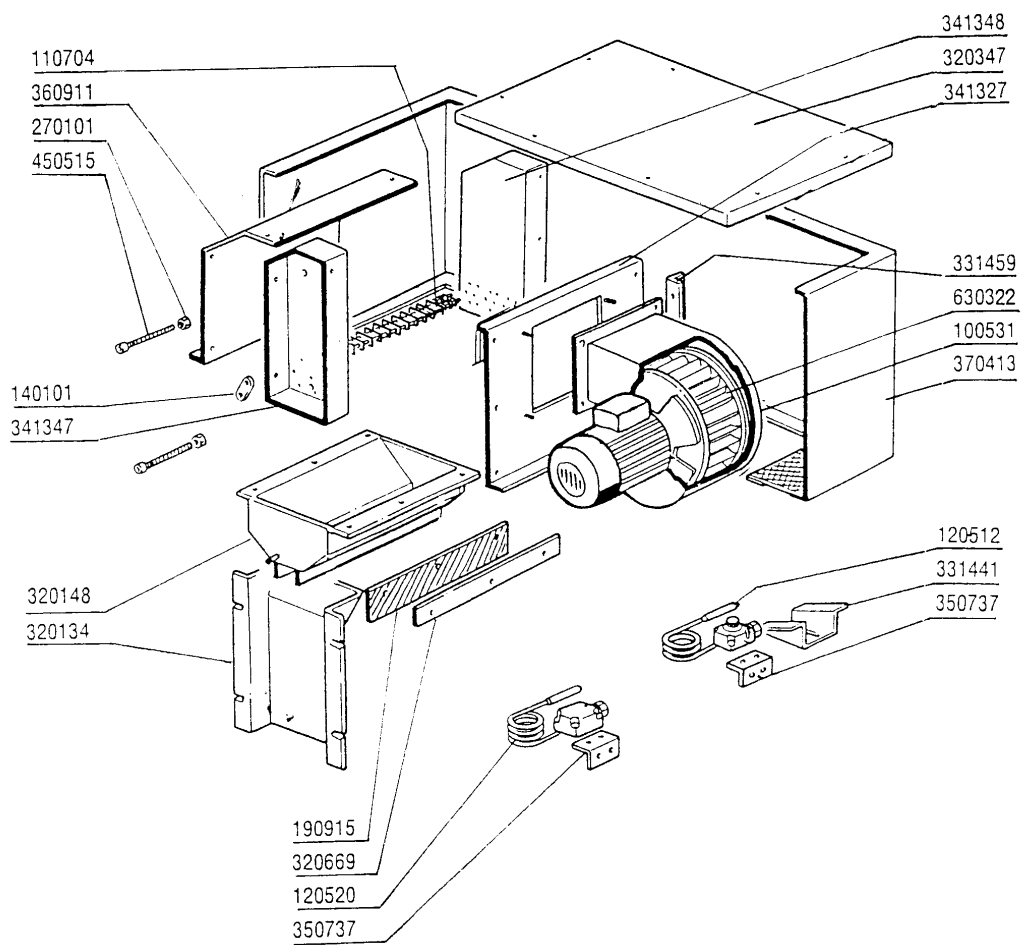

**27 - Blower Dryer**

<b>CODE</b>	<b>DESCRIPTION</b>
100531	FAN HP1,5-220/380/415-BPN9
110704	HEAT.ELEMENT/DRYING 1000W 220V
120512	THERMOSTAT IM50/210Ø
120520	SECURITY THERMOSTAT 110-130Ø
140101	BRASS CONNECT. PLATE HEAT.ELEM
190915	FIXING PLATE
270101	HEXAGON LOCK NUT 1/2"
320134	DRYER DEFLECTOR
320148	DEFLECTOR F. DRYER
320347	COVER FOR DRYER
320669	FIXING PLATE
331441	BRACKET FOR DRYING VENTILATOR
331459	BRACKET FOR DRYING VENTILATOR
341327	FAN SUPPORT
341347	RIGHT SUPPORT
341348	LEFT SUPPORT
350737	BRACKET FOR CLOSED THERMOSTATS
360911	PANEL
370413	DRYING MODULE
450515	STAINL.ST.SHIELD FOR 1 THERMOS
630322	FAN IMPELLOR 1,5HP BPN9S

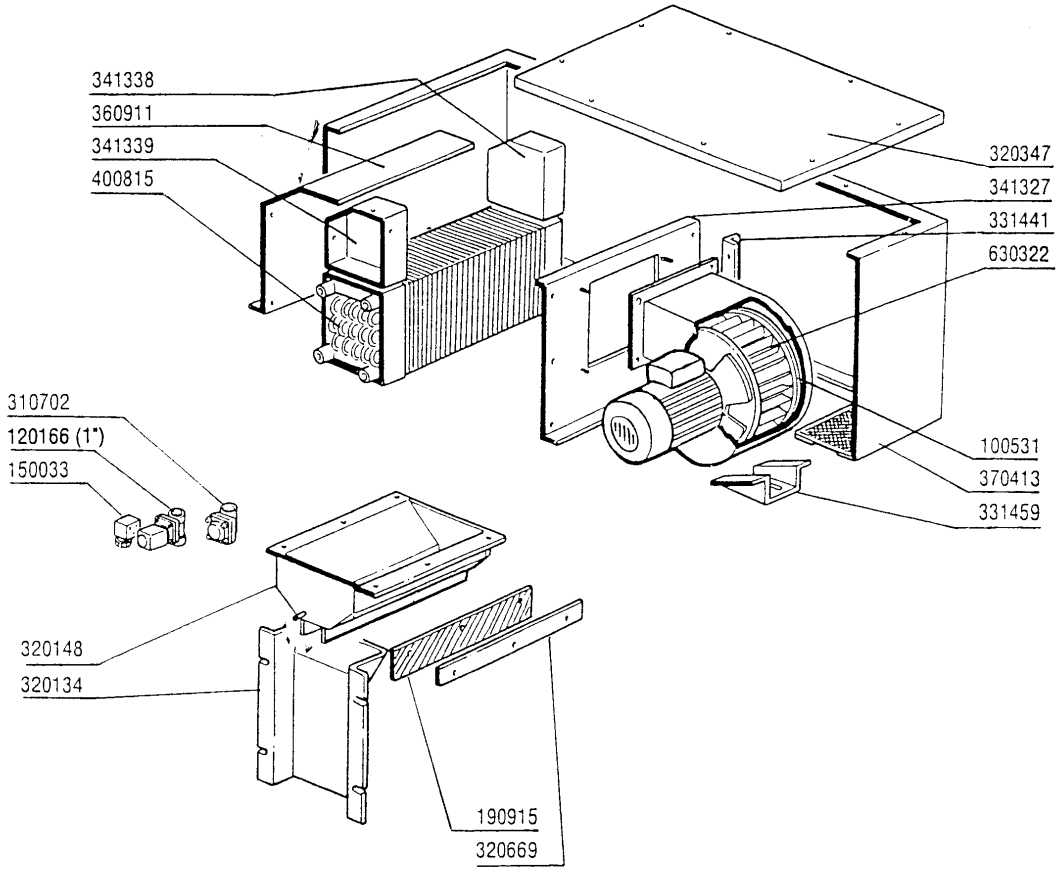

## 28 - Steam Blower Dryer

<b>CODE</b>	<b>DESCRIPTION</b>
100531	FAN HP1,5-220/380/415-BPN9
120166	STEAM SOLEN.VALVE 1" 24V-50
150033	CONNEC.F.SOLEN.VALVE 182.09.N
190915	FIXING PLATE
310702	STEAM TRAP 1/2" MK 25/3
320134	DRYER DEFLECTOR
320148	DEFLECTOR F. DRYER
320347	COVER FOR DRYER
320669	FIXING PLATE
331441	BRACKET FOR DRYING VENTILATOR
331459	BRACKET FOR DRYING VENTILATOR
341327	FAN SUPPORT
341338	RIGHT PANEL
341339	LEFT PANEL
360911	PANEL
370413	DRYING MODULE
400815	BATTERY FOR DRYING (9-12KW) SE
630322	FAN IMPELLOR 1,5HP BPN9S

29 - Heat recovery unit

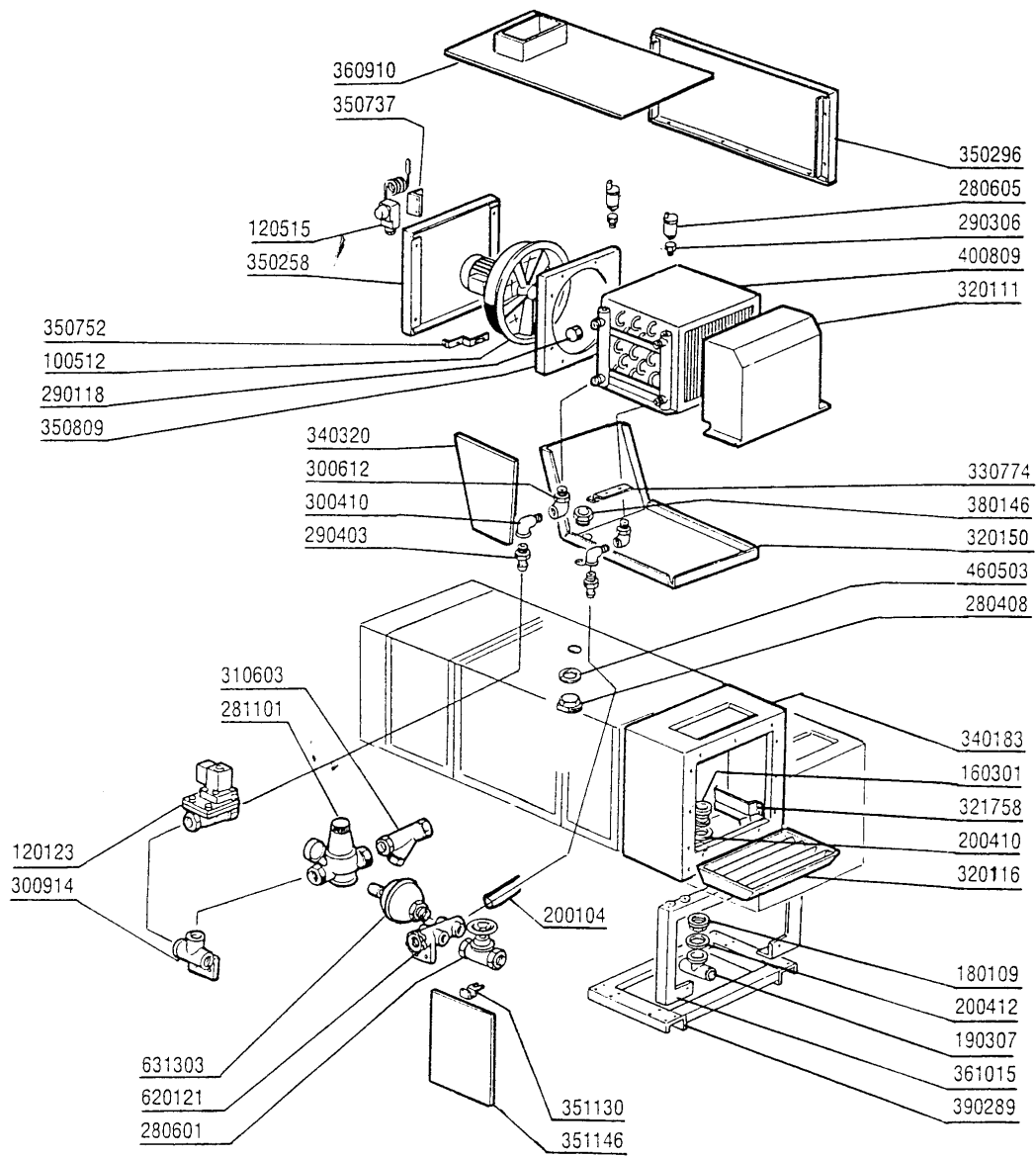

29 - Heat recovery unit

CODE	DESCRIPTION
100512	FAN HP 0,75 400EVH/4/27
120123	SOLENOID VALVE L180B12 1" V.24
120515	THERMOSTAT 0-90°C
160301	DRAIN OUTLET 1"1/2 C-S-N
180109	LOCK NUT 1 1/2"
190307	SPECIAL TEE GRAU MPL.
200104	DISCHARGE HOSE 20X30
200410	DRAIN OUTL.WASH.1 1/2"65X47X2
200412	GASKET DRAIN 11/2" 45X33X3
280408	NUT
280601	GATE VALVE 1/2" BRASS
280605	AUTOMATIC AIR VENT 1/4" GAS
281101	3/4" ADJ VALVE C/W GAUGE
290118	BRASS TE PLUG 3/4"
290306	CONNECTION 1/4 MF
290403	NIPPLE M.3/4" BRASS
300410	ELL 3/4" MF
300612	UNION ELL 3/4" F-F
300914	TEE 1"
310603	STRAINERS JU 1" MOD.45
320111	DEFLECTOR F. HRU
320116	DEFLECTOR
320150	BREAKER
321758	GUIDE
330774	BRACKET
340183	HOOD
340320	PANEL
350258	PANEL
350296	PANEL
350737	BRACKET FOR CLOSED THERMOSTATS
350752	BRACKET
350809	SUPPORT
351130	BRACKET FOR PANEL S-SE
351146	FRONT/BACK PANEL HEAT RECOVERY
360910	COVER
361015	FRAME
380146	CONDENSER UNIT DRAIN CONNECTIO
390289	FRAME
400809	CONDENSER BATTERY ENERGY REC.
460503	SEALING WASHER 38X27X2(3/4)
620121	TWIN SOLENOID VALVE MANIFOLD
631303	HYDRAULIC AIR VESSEL FOR HEAT



30 - Heat Recovery Unit Compact

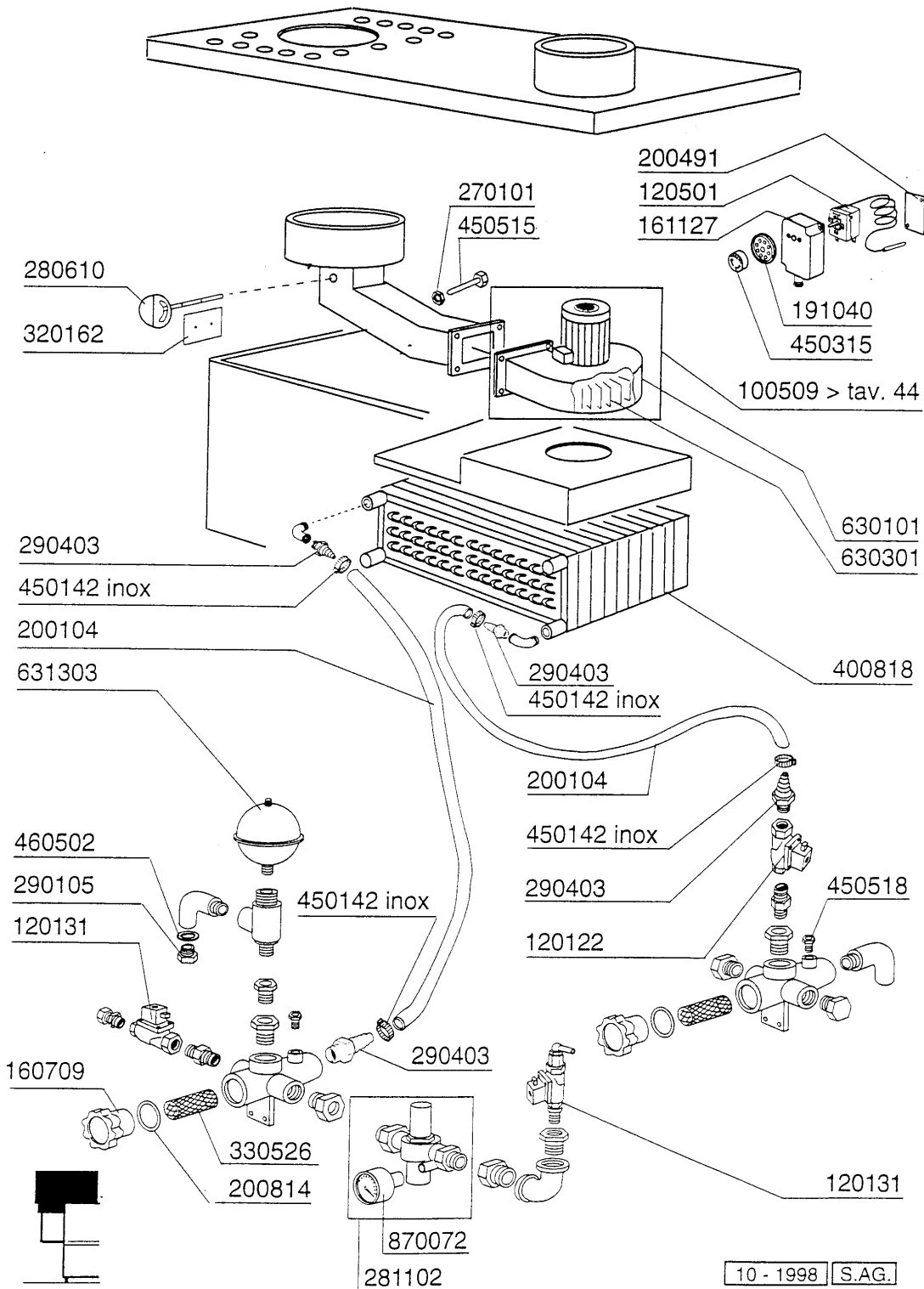

### 30 - Heat Recovery Unit Compact

CODE	DESCRIPTION
100509	FAN 0,75HP 220/415 V164/2
120122	SOLENOID VALVE 3/4 24V L180Q17
120131	SOLEN. L182Q31-ZB10A 1/2"24V
120501	THERMOSTAT 30/90°C
160709	KNOB OF MANIFOLD F. SOLEN. VAL
161127	BOX FOR THERMOSTAT
191040	FRAME F.THERMOSTAT KNOB
200104	DISCHARGE HOSE 20X30
200491	BACK GASKET OF THERMOSTAT BOX
200814	O-RING 34,52X41,58X3,53
270101	HEXAGON LOCK NUT 1/2"
280610	VALVE FOR HEAT RECOVERY UNIT
281102	1/2" ADJ VALVE C/W GAUGE TYPE
290105	BRASS-TE-PLUG 1/2"
290403	NIPPLE M.3/4" BRASS
320162	BREAKER
330526	FILTERS 22X28 SOLENOID V.MANIF
400818	BATTERY FOR HRU (SMALL)
450142	CLAMP FE ZN. 22-32 H=12,2
450315	KNOB F. THERMOSTAT 90°
450515	STAINL.ST.SHIELD FOR 1 THERMOS
450518	THERMOSTAT SHIELD FOR SNL
460502	GASKET 30X21X2
630101	ZINC VOLUTE CB62
630301	FAN IMPELLOR FOR 100509
631303	HYDRAULIC AIR VESSEL FOR HEAT
870072	PRESSURE CAUGE 0-4 ATM

## 31 - Door counterbalance

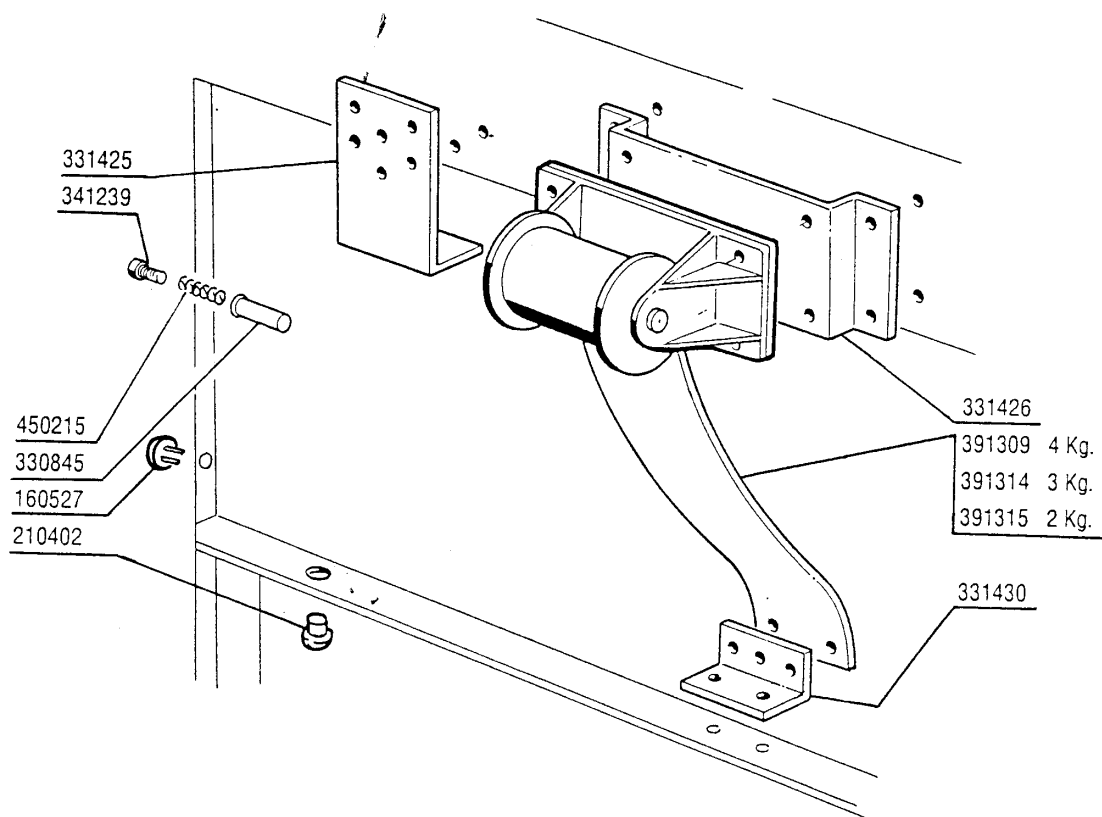

## 31 - Door counterbalance

<b>CODE</b>	<b>DESCRIPTION</b>
160527	PLUG 14,5X2X8
210402	PAD FOR DOOR 15-149
330845	BUSH FOR DOOR FRICTION RAIL N
331425	DOOR CATCH BRACKET SE
331426	BRACKET F. HOOD SPRING FIXING
331430	BRACKET FOR DOOR SPRING
341239	PIN F.DOOR FRICTION RAIL N S
391309	DOOR SPRING 4KG - 40MM
391314	DOOR SPRING 3KG - 40MM
391315	DOOR SPRING 2,5KG - 40MM
450215	SPRING F.SWITCH ROD R/B41-11-2

- 321377 1200
- 321375 1500
- 321378 1700
- 321387 2000

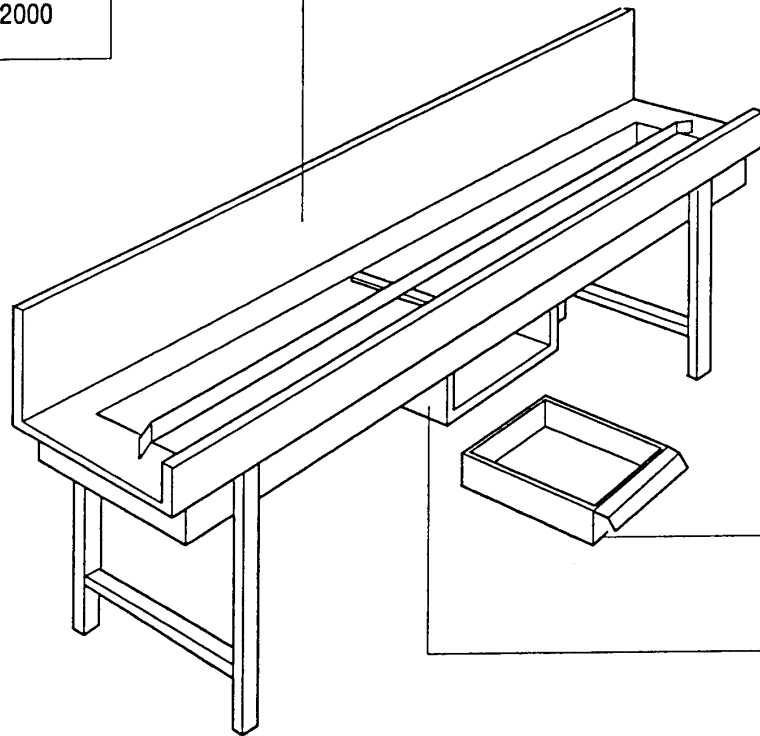

332000

350434

1 - 4 - 95

**32 - Straight through unit**

<b>CODE</b>	<b>DESCRIPTION</b>
321375	1500 MM UNIT
321377	1200 MM UNIT
321378	1700 MM UNIT
321387	STRAIGHT THROUGH UNIT
332000	FILTER FOR GMC
350434	TANK

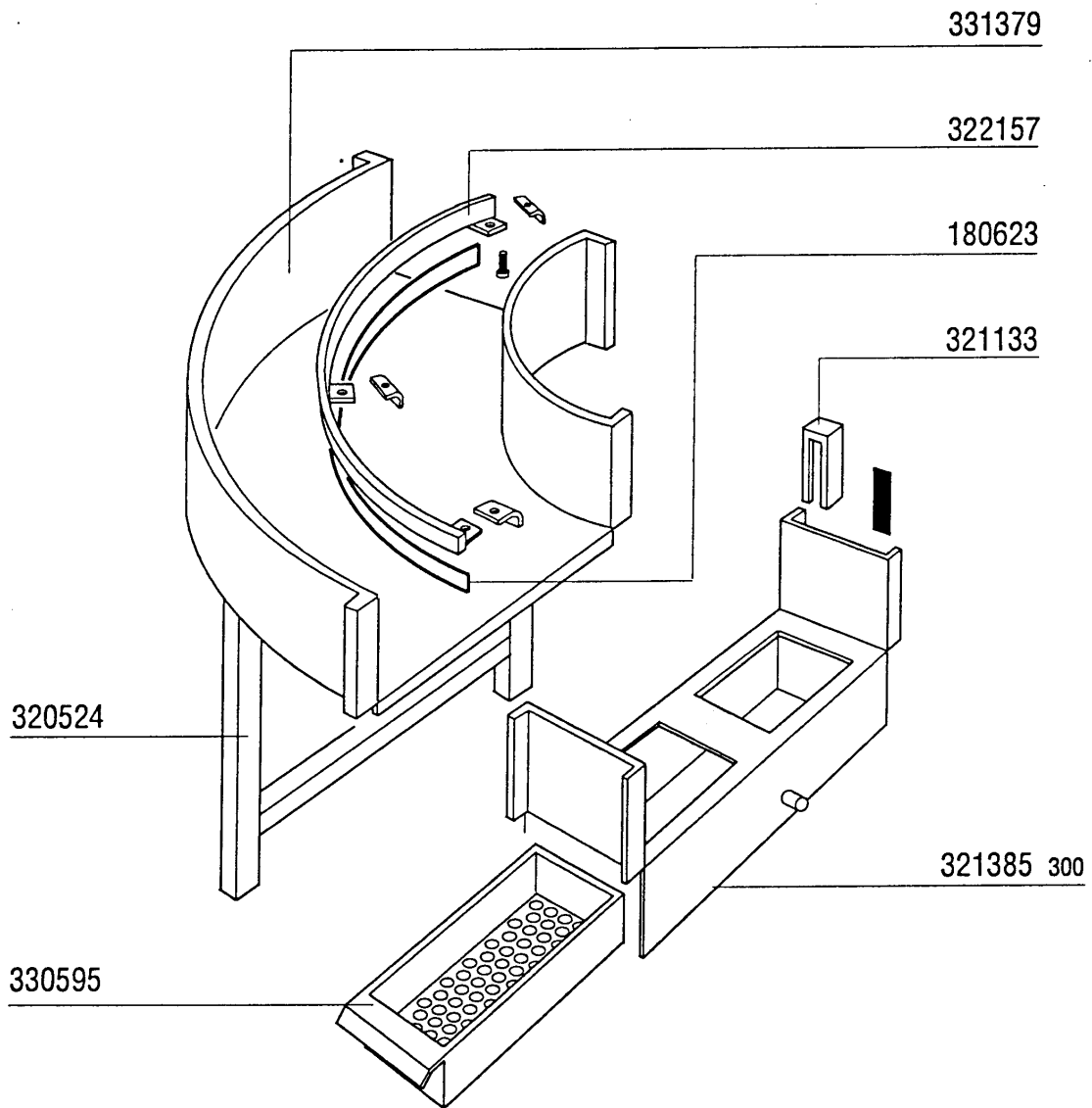

1 - 4 - 95

<b>CODE</b>	<b>DESCRIPTION</b>
180623	CHAIN SUPPORT FOR GMC MACHINES
320524	LEGS
321133	COVER
321385	ENTRY UNIT
322157	GUIDE
330595	FILTER
331379	-TUBO COLL.RIDUTT.1/2"XS90 VAP



MOD.	1° lavaggio 1 <sup>st</sup> lavage 1 <sup>st</sup> wash 1. Waschzone 1° lavado 900	2° lavaggio 2 <sup>nd</sup> lavage 2 <sup>nd</sup> wash 2. Waschzone 2° lavado 600	2° lavaggio 2 <sup>nd</sup> lavage 2 <sup>nd</sup> wash 2. Waschzone 2° lavado 900	3° lavaggio 3 <sup>rd</sup> lavage 3 <sup>rd</sup> wash 3. Waschzone 3° lavado 600	Ecorinse	Risciacquo Rincage Rinse Nachspülung Aclarado
GMC 2700	2 x 6 kw				1 x 4,2 kw	1 x 14 kw
2700 AF	2 x 6 kw				1 x 4,2 kw	3 x 10 kw
GMC 3500	2 x 6 kw				1 x 5 kw	2 x 9 kw
3500 AF	2 x 6 kw				1 x 5 kw	3 x 9 kw 1 x 6 kw *
3500 RC	2 x 6 kw				1 x 5 kw	2 x 6 kw 1 x 9 kw
GMC 4500	2 x 5 kw	2 x 6 kw			1 x 5 kw	2 x 6 kw 1 x 9 kw
4500 AF	2 x 5 kw	2 x 6 kw			1 x 5 kw	3 x 10 kw 1 x 8 kw *
4500 RC	2 x 5 kw	2 x 6 kw			1 x 5 kw	1 x 6 kw 1 x 8 kw 1 x 9 kw
GMC 5500	2 x 5 kw		2 x 6 kw	2 x 6 kw	1 x 6 kw	3 x 8 kw
5500 AF	2 x 5 kw		2 x 6 kw	2 x 6 kw	1 x 6 kw	2 x 6 kw 1 x 9 kw 2 x 6 kw* 1 x 9 kw *
5500 RC	2 x 5 kw		2 x 6 kw	2 x 6 kw	1 x 6 kw	1 x 6 kw 1 x 8 kw 1 x 9 kw

	220/380	240/415
4,2 kw	110331	110331
5 kw	110371	110354
6 kw	110349	110383
8 kw	110343	110365
9 kw	110362	110343
10 kw	110388	110381
14 kw	110386	

\* 2° Boiler  
2<sup>ème</sup> surchauffeur  
2<sup>nd</sup> boiler  
2. Boiler  
2° boiler

## 34 - Heating Elements

CODE	DESCRIPTION
110331	HEAT.ELEMENT 4200W 230/400V
110343	HEAT.ELEM. 8000W 220/380V
110349	HEAT.ELEMENT 6000W 230/400V
110354	HEAT.ELEMENT 6000W 255/440V
110362	HEAT.ELEMENT 9000W 220/380V
110365	HEAT.ELEM. 9000W 255/440V-8KW
110371	HEAT.ELEMENT 5000W 220/380V
110381	HEAT.ELEMENT 12500W 254/440V
110383	HEAT.ELEMENT 6KW 240/415
110386	HEAT.ELEMENT14KW 230/400V
110388	HEAT.ELEMENT 10000W 230/400V

## 35 - Electrical parts for heatings elements

kw	220/240 V				380/415 V			
	A	FUSIBILI FUSIBLE FUZE SCHMELZSICHERUNG FUSIBLE	A	TALERUTTORE CONTACTEUR CONTACTOR SCHALTSCHÜTZ CONTACTOR	A	FUSIBILI FUSIBLE FUZE SCHMELZSICHERUNG FUSIBLE	A	TALERUTTORE CONTACTEUR CONTACTOR SCHALTSCHÜTZ CONTACTOR
3,00	12	130246	9	120428	8	130245	9	120428
4,00	12	130246	9	120428	8	130245	9	120428
4,20	12	130246	9	120428	8	130245	9	120428
5,00	16	130247	12	120429	12	130246	9	120428
6,00	20	130248	12	120429	12	130246	9	120428
8,00	32	130237	25	120437	16	130247	12	120429
9,00	32	130237	25	120437	16	130247	16	120430
10,00	32	130237	25	120437	20	130248	16	120430
12,00	40	130238	40	120431	25	130236	16	120430
12,50	40	130238	40	120431	25	130236	25	120437
14,00	40	130238	40	120431	32	130237	25	120437
15,00	50	130257	40	120431	32	130237	25	120437
16,00	50	130257	40	120431	32	130237	25	120437
17,00	50	130257	40	120431	32	130237	40	120431
18,00	63	130239	63	120431	32	130237	40	120431
20,00	63	130239	63	120433	40	130238	40	120431
21,00	63	130239	63	120433	40	130238	40	120431
22,00	63	130239	63	120433	40	130238	40	120431
23,00	80	130240	63	120433	40	130238	40	120431
24,00	80	130240	63	120433	50	130257	40	120431
25,00	80	130240	63	120433	50	130257	40	120431
26,00	80	130240	80	120441	50	130257	40	120431
27,00	80	130240	80	120441	50	130257	40	120431
28,00	80	130240	80	120441	50	130257	40	120431
29,00	80	130240	80	120441	50	130257	40	120431
30,00	80	130240	80	120441	50	130257	40	120431

ASCIUGATURA - SECHAGE - DRYER  
TROCKNUNG - SECADO

kw	220/240 V				380/415 V			
	A	FUSIBILI FUSIBLE FUZE SCHMELZSICHERUNG FUSIBLE	A	TALERUTTORE CONTACTEUR CONTACTOR SCHALTSCHÜTZ CONTACTOR	A	FUSIBILI FUSIBLE FUZE SCHMELZSICHERUNG FUSIBLE	A	TALERUTTORE CONTACTEUR CONTACTOR SCHALTSCHÜTZ CONTACTOR
6	20	130248	12	120429	12	130246	12	120429
9	25	130236	25	120437	16	130247	25	120437
12	40	130238	40	120431	25	130236	25	120437

### 35 - Electrical parts for heatings elements

CODE	DESCRIPTION
120428	CONTACTOR 9A 24V 50HZ
120429	CONTACTOR 12A 24V 50HZ
120430	CONTACTOR 17A 24V 50HZ
120431	CONTACTOR 40A 24V 50HZ
120433	CONTACTOR 63A 24V 50HZ
120437	CONTACTOR 25A 24V 50HZ
120441	CONTACTOR 80AMP 24V 50HZ
130236	FUSE 14X51 25A GF14325
130237	FUSE 14X51 32A GL14332
130238	FUSE 14X51 40A GF 14340
130239	FUSE 22X58 63A GF15363
130240	FUSE 22X58 80A GF15380
130245	FUSE 10.3X38 8A GF13308
130246	FUSE 10.3X38 12A GF13312
130247	FUSE 10.3X38 16A GF13316
130248	FUSE 20A-10,3X38 13320 G.F.
130257	FUSE 50A 14X51 GF14350

220/240 V								380/415 V					
POMPA POMPE PUMP PUMPE BOMBA		FUSIBILI FUSIBLE FUSE SCHMELZSICHERUNG FUSIBLE		TELERUTTORE CONTACTEUR CONTACTOR SCHALTSCHÜTZ CONTACTOR		TERMICA TERMIQUE OVERLOAD RELAY THERMOAUFLÖSER TERMICO		FUSIBILI FUSIBLE FUSE SCHMELZSICHERUNG FUSIBLE		TELERUTTORE CONTACTEUR CONTACTOR SCHALTSCHÜTZ CONTACTOR		TERMICA TERMIQUE OVERLOAD RELAY THERMOAUFLÖSER TERMICO	
HP	kw												
0,10	0,08	4	130230	9	120428	0,63 - 1,00	120820	4	130230	9	120428	0,40 - 0,63	120830
0,12	0,09	4	130230	9	120428	0,63 - 1,00	120820	4	130230	9	120428	0,40 - 0,63	120830
0,15	0,11	4	130230	9	120428	0,63 - 1,00	120820	4	130230	9	120428	0,63 - 1,00	120820
0,17	0,12	4	130230	9	120428	1,00 - 1,60	120821	4	130230	9	120428	0,63 - 1,00	120820
0,2	0,15	4	130230	9	120428	1,00 - 1,60	120821	4	130230	9	120428	0,63 - 1,00	120820
0,22	0,17	4	130230	9	120428	1,00 - 1,60	120821	4	130230	9	120428	0,63 - 1,00	120820
0,25	0,18	4	130230	9	120428	1,60 - 2,50	120822	4	130230	9	120428	1,00 - 1,60	120821
0,4	0,30	4	130230	9	120428	1,60 - 2,50	120822	4	130230	9	120428	1,00 - 1,60	120821
0,5	0,37	4	130230	9	120428	1,60 - 2,50	120822	4	130230	9	120428	1,00 - 1,60	120821
0,6	0,44	4	130230	9	120428	2,50 - 4,00	120823	4	130230	9	120428	1,00 - 1,60	120821
0,75	0,55	4	130230	9	120428	2,50 - 4,00	120823	4	130230	9	120428	1,60 - 2,50	120822
1	0,75	4	130230	9	120428	2,50 - 4,00	120823	4	130230	9	120428	1,60 - 2,50	120822
1,01	0,76	4	130230	9	120428	2,50 - 4,00	120823	4	130230	9	120428	1,60 - 2,50	120822
1,4	1,10	8	130232	9	120428	4,00 - 6,00	120824	6	130231	9	120428	2,50 - 4,00	120823
1,5	1,11	8	130232	9	120428	4,00 - 6,00	120824	6	130231	9	120428	4,00 - 6,00	120823
2	1,50	8	130232	9	120428	5,50 - 8,00	120825	6	130231	9	120428	4,00 - 6,00	120823
2,7	2,00	8	130232	9	120428	5,50 - 8,00	120825	6	130231	9	120428	4,00 - 6,00	120823
3	2,20	12	130234	9	120428	7,00 - 10,00	120828	6	130231	9	120428	4,00 - 6,00	120823
3,2	2,40	12	130234	12	120429	7,00 - 10,00	120828	6	130231	9	120428	4,00 - 6,00	120823
3,5	2,60	12	130234	12	120429	10,00 - 13,00	120826	6	130231	9	120428	5,50 - 8,00	120825
3,6	2,70	16	130235	12	120429	10,00 - 13,00	120826	8	130232	9	120428	5,50 - 8,00	120825
3,70	2,72	16	130235	12	120429	10,00 - 13,00	120826	6	130231	9	120428	5,50 - 8,00	120825
4,0	3,00	16	130235	16	120430	10,00 - 13,00	120826	12	130234	12	120429	5,50 - 8,00	120825
5,3	4,00	20	130235	18		13,00 - 18,00		16	130235	12	120429	7,00 - 10,00	120828

## 36 - Electrical parts for pumps

CODE	DESCRIPTION
120428	CONTACTOR 9A 24V 50HZ
120429	CONTACTOR 12A 24V 50HZ
120430	CONTACTOR 17A 24V 50HZ
120820	OVERLOAD RELAY 0,63-1A
120821	OVERLOAD RELAY 1/1,6A
120822	OVERLOAD RELAY 1,6-2,5A
120823	OVERLOAD RELAY 2.5/4 A
120824	OVERLOAD RELAY 4/6 A
120825	OVERLOAD RELAY 5,5/8 A
120826	OVERLOAD RELAY 10/13A
120828	OVERLOAD RELAY 7/10 A
120830	OVERLOAD RELAY 0,40 - 0,63 A
130230	FUSE 10,3X38 4A AM13004
130231	FUSE 10,3X38 6A AM13006
130232	FUSE 10.3X38 8A AM13008
130234	FUSE 10.3X38 12A AM13012
130235	FUSE 10.3X38 16A AM13016

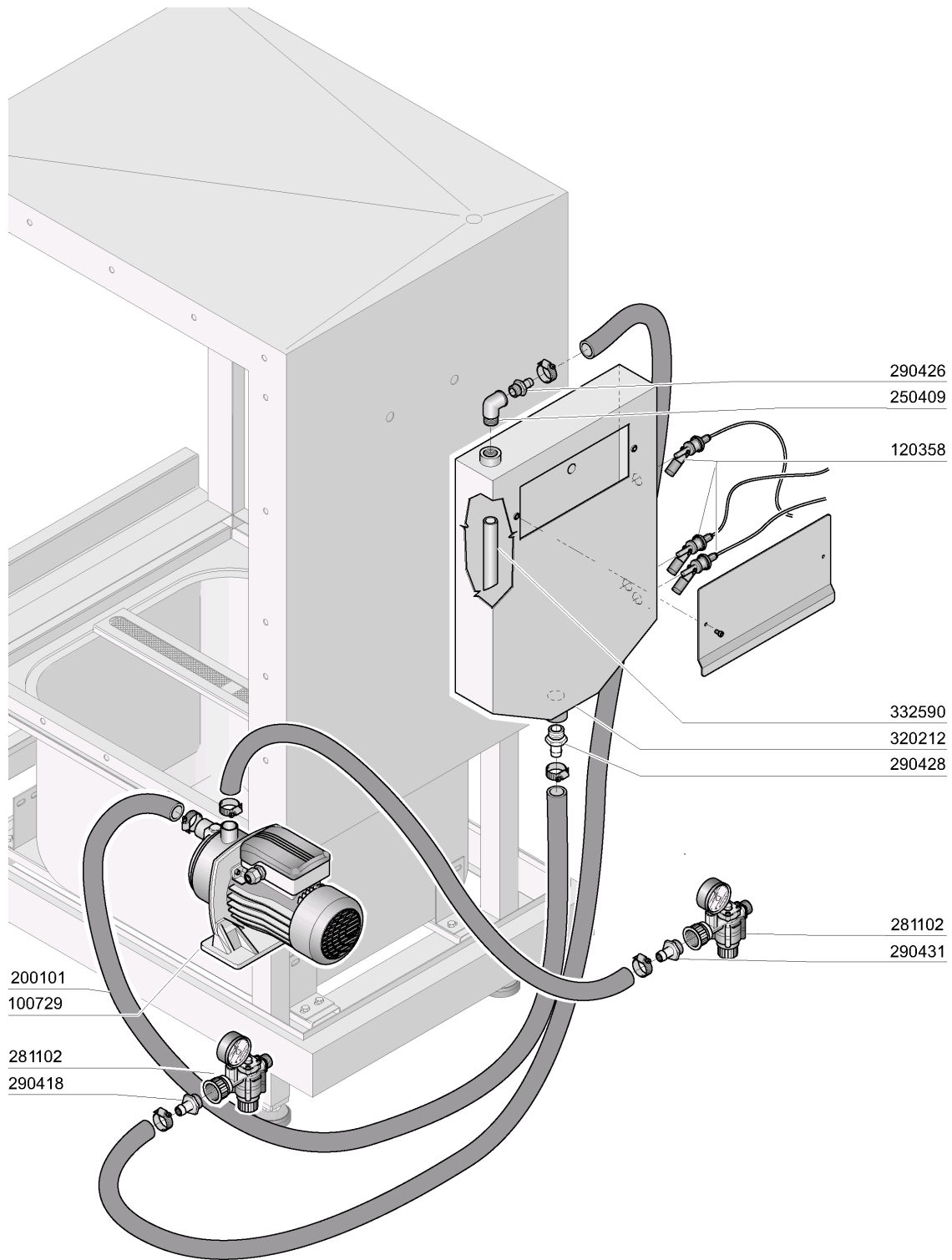

37 - Break tank\_TR

CODE	DESCRIPTION
100729	PUMP HP 0,4 220/240V 2HM3T
120358	FLOATING MAGN.SWITCH
200101	RUBBER TUBE 25X35
250409	INOX ELL FF 1/2"
281102	1/2" ADJ VALVE C/W GAUGE TYPE
290418	NIPPLE 1/2"
290426	NIPPLE 1/2"
290428	NIPPLE M.3/4"
290431	NIPPLE 1/2"
320212	BREAK TANK BOX
332590	STAINLESS STEEL HOSE FOR B.T.



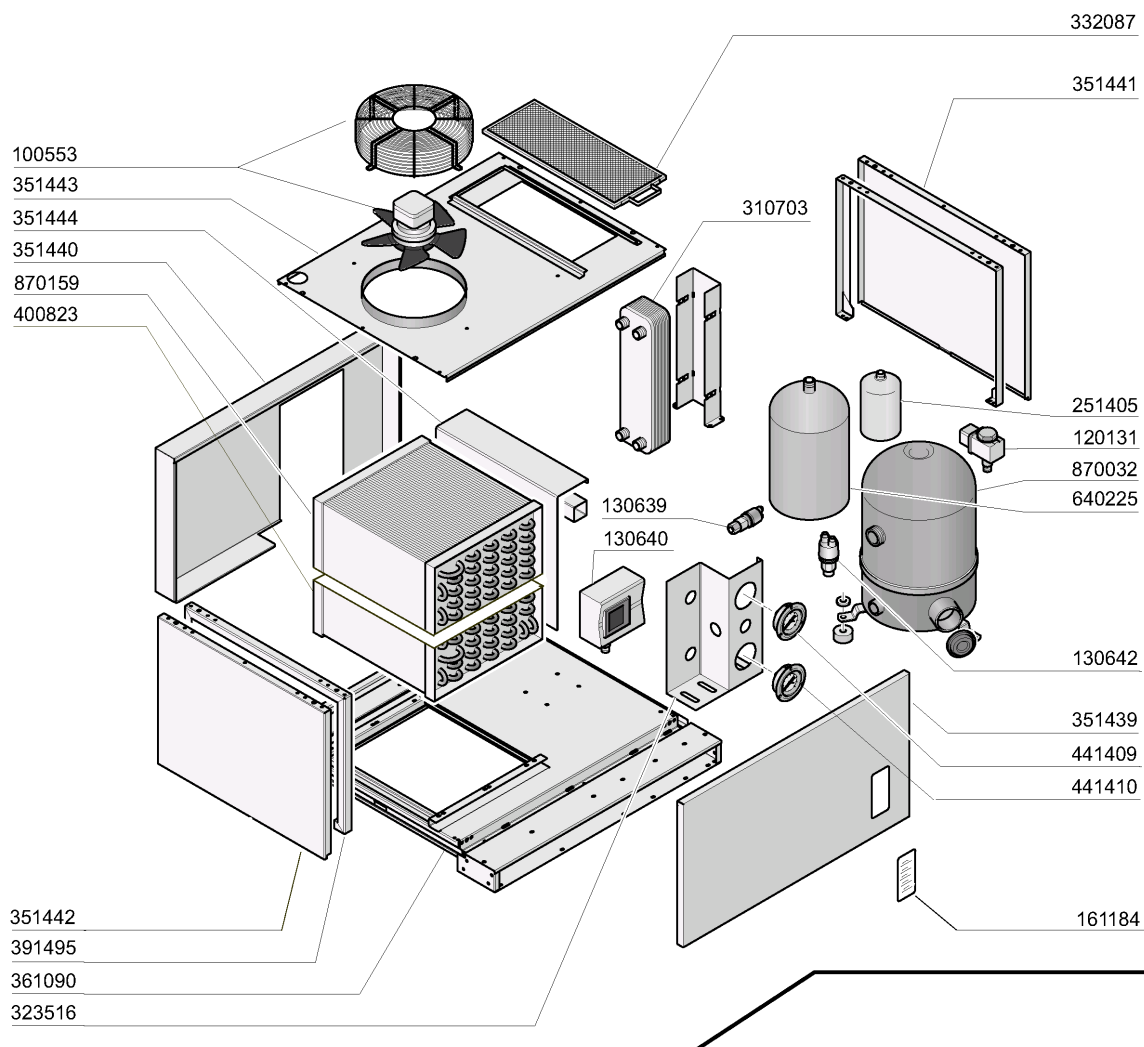

- ① - A x B x C = 298 x 423 x 490 = CODE 870159/RIV
- ① - A x B x C = 230 x 400 x 450 = CODE 870159
- ② - D x E x F = 142 x 490 x 423 = CODE 400823/RIV
- ② - D x E x F = 140 x 450 x 450 = CODE 400823

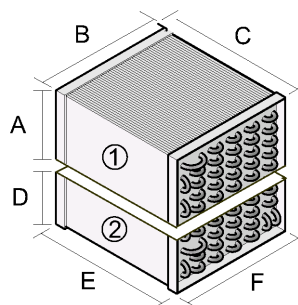

## 38 - Heat pumps WP4

CODE	DESCRIPTION
100553	WP4 FAN
120131	SOLEN. L182Q31-ZB10A 1/2"24V
130639	LOW PRESSURE SWITCH WP
130640	HIGH PRESSURE SWITCH WP
130642	PRESSURE SWITCH WP4-LOW PRESS.
161184	MANOMETER INSPECTION GLASS
251405	FILTER WP4
310703	RINSE WATER CONDENSOR
323516	MANOMETER SUPPORT
332087	WP4 COVER FILTER
351439	FRONT PANEL 750 MM
351440	BACK PANEL 750MM
351441	ENTRY PANEL 750MM
351442	EXIT PANEL 750MM
351443	UPPER PANEL 750MM
351444	PARZIALIZZATORE WP 750MM
361090	BASEMENT WP4
391495	LEFT SIDE HOOD
400823	BATTERY WP4
400823/RIV	BATTERY WP4
441409	MANOMETRO ASPIRAZIONE (WP)
441410	MANOMETRO CONDENSAZIONE (WP)
640225	LIQUID GAS CONTAINER FOR WP4
870032	COMPRESSOR WP4
870159	EVAPORATOR WP4
870159/RIV	EVAPORATOR WP4

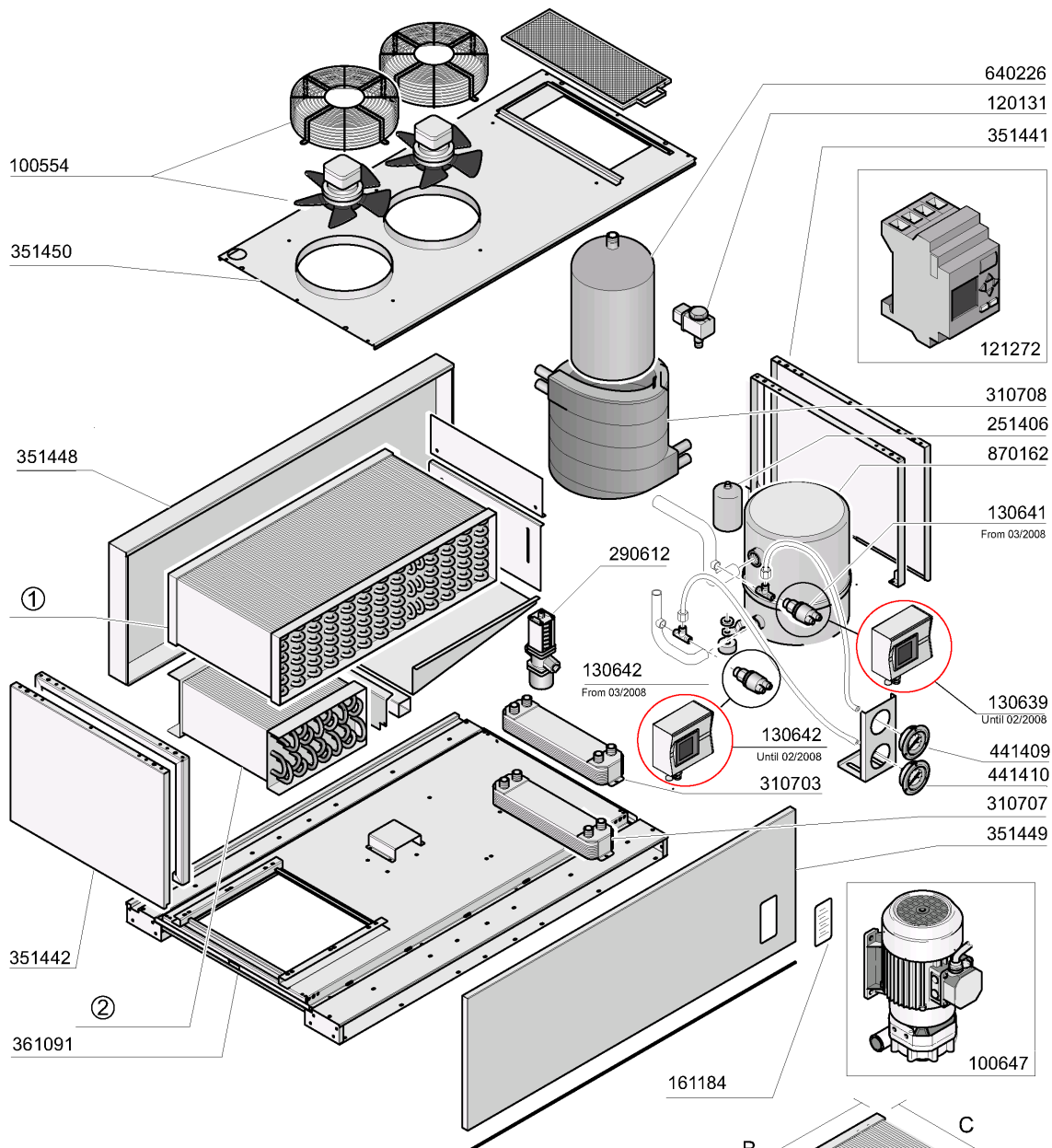

- ① A x B x C = 250 x 800 x 460 = CODE 870164/RIV
- ① A x B x C = 175 x 750 x 450 = CODE 870164
- ② D x E x F = 190 x 460 x 460 = CODE 400824/RIV
- ② D x E x F = 175 x 450 x 450 = CODE 400824

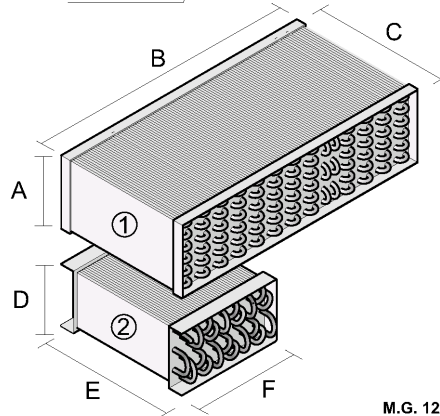

M.G. 12/09

## 39 - Heat pumps WP6

CODE	DESCRIPTION
100554	WP6/WP8 FAN
100647	PUMP HP 0,20 220/240/3 4226
120131	SOLEN. L182Q31-ZB10A 1/2"24V
121272	PLC
130639	LOW PRESSURE SWITCH WP
130641	PRESSOS WP4 LOW PRESS 2.2 BAR
130642	PRESSURE SWITCH WP4-LOW PRESS.
161184	MANOMETER INSPECTION GLASS
251406	FILTER WP6-WP8
290612	VALVOLA PRESSOSTATICA(WP6-WP8)
310703	RINSE WATER CONDENSOR
310707	CONDENS.GAS/ACQUA BY-PASS (WP)
310708	CONDENSER (WP)
351441	ENTRY PANEL 750MM
351442	EXIT PANEL 750MM
351448	BACK PANEL 1250MM WP
351449	1250MM WP FRONT PANEL
351450	UPPER PANEL 1250MM
361091	BASEMENT WP6
400824	BATTERY WP6
400824/RIV	BATTERY WP6
441409	MANOMETRO ASPIRAZIONE (WP)
441410	MANOMETRO CONDENSAZIONE (WP)
640226	LIQUID GAS CONTAINER FOR WP6-8
870162	COMPRESSOR WP6
870164	EVAPORATOR WP6
870164/RIV	EVAPORATOR WP6